



National Fenestration Rating Council Incorporated

NFRC 200-2004_[E1A4]

Procedure for
Determining Fenestration Product Solar Heat Gain Coefficient and
Visible Transmittance at Normal Incidence

© 2004 NATIONAL FENESTRATION RATING COUNCIL, INC.

PREPARED BY:

National Fenestration Rating Council
6305 Ivy Lane, Suite 140
Greenbelt, MD 20910
Voice: (301) 589-1776
Fax: (301) 589-3884
Email: info@nfr.org
Website: www.nfr.org



FOREWORD

This procedure has been developed by the National Fenestration Rating Council (NFRC) to meet the need for a uniform and accurate means for calculating Solar Heat Gain Coefficients (SHGCs) and Visible Transmittances (VTs) of fenestration products. The SHGC is calculated in accordance with ISO 15099, except where noted, or measured using NFRC 201 at a fixed set of environmental conditions and at normal incidence radiation. Consequently, the SHGC calculated using this procedure may not be appropriate for determining peak solar heat gains for other angles of direct beam incidence, nor for determining the solar heat gain produced by diffuse radiation incident on the fenestration system, nor for determining seasonal energy performance. The VT is also determined for normal incidence direct beam radiation and may not be appropriate for determining daylighting impacts or view through a fenestration product at other angles of incidence.

Consumers today have many new energy-saving fenestration product options to choose from. Advances in fenestration product technologies include the use of low-emissivity coatings, dynamic glazing, selective tints, insulating spacers and new frame materials and designs. While the use of one or more of these components can improve fenestration product thermal performance it will also increase the complexity of the selection process. This procedure is offered as a uniform means to calculate total fenestration product SHGCs and VTs for the class of fenestration products that lend themselves to this calculation. It is hoped that in the future, the scope of this calculation procedure can be extended to include an even greater variety of fenestration products.

This document supersedes and replaces NFRC 200-2001. This document contains the state-of-the-art procedure at the time of its publication. This procedure will be updated as new research results become available and accepted. This is a metric document (SI); inch-pound (IP) units are for reference only.

Questions on the use of this procedure should be addressed to:

<p>National Fenestration Rating Council 6305 Ivy Lane, Suite 140 Greenbelt, MD 20770 Voice: (301) 589-1776 Fax: (301) 589-3884 Email: info@nfr.org Website: www.nfr.org</p>
--



Table of Contents

Foreword		ii
1. Purpose		1
2. Scope		1
2.1 PRODUCTS COVERED		1
2.1.1 Products Covered using NFRC 201 Test Procedure for SHGC		2
2.2 PRODUCTS AND EFFECTS NOT COVERED		3
2.2.1 Products and Effects Not Covered (SHGC).....		3
2.2.2 Products and Effects Not Covered (VT).....		3
3. Definitions		4
4. General		6
4.1 COMPLIANCE		6
4.1.1 Product Line Simulation and Testing		6
4.1.2 Testing Alternative.....		7
4.2 PRODUCT LINES AND INDIVIDUAL PRODUCTS.....		7
4.2.1 Product Lines		7
4.2.2 Individual Products		7
4.2.3 Grouping of Products.....		7
4.3 STANDARD CONDITIONS		8
4.3.1 Simulation.....		8
4.3.2 Testing.....		9
4.3.3 Environmental Conditions during NFRC 201 Testing		9
4.3.3.1 Center-of-Glazing Component Test Procedure		9
4.4 MODEL SIZES AND CONFIGURATIONS		9
4.5 SIMULATION PROCEDURES.....		10
Table 4-1 Representative Glazing Pane Thicknesses		12
4.5.1 Component.....		12
4.5.1.1 Approved Center-of-Glazing Simulation Program.....		12
4.5.1.2 Approved 2-D Heat Transfer Simulation Program.....		12
4.6 TEST PROCEDURES.....		12
4.6.1 Total Fenestration Product.....		13
4.6.2 Component.....		13
4.7 TOTAL FENESTRATION PRODUCT RATING		13

5.	Variation From The General Requirements	15
5.1	WINDOW AND SLIDING GLASS DOORS	15
5.2	SWING DOORS.....	15
	5.2.1 Calculation of Total Product Rating	15
	5.2.1.1 Simplification.....	16
5.3	SKYLIGHTS	16
5.4	TUBULAR DAYLIGHTING DEVICES	16
5.5	GARAGE (VEHICULAR ACCESS) DOORS	16
5.6	SITE BUILT.....	16
5.7	COMBINATION FENESTRATION ATTACHMENT PRODUCTS:	16
	5.7.1 Scope	16
	5.7.2 Variations from Standard Product Lines.....	17
	5.7.3 Variations from Standard Individual Products	17
	5.7.4 Variations from Standard Simulation and Test Conditions	17
	5.7.4.1 Approved Center-of-Glazing Computational Program.....	17
	Table 5-1 Center-of-Glazing Values SHGC _c and VT _c	18
	5.7.5 Calculation of Total Product Rating	18
	Table 5-2 Values of SHGC ₀ and SHGC ₁ and VT ₀ and VT ₁ for Reference Products	18
	5.7.5.1 Reference Fenestration Products.....	18
	Table 5-3 Values of SHGC and VT for Reference and Combination Fenestration Attachment Products	19
	5.7.5.2 Total Fenestration Product SHGC	19
	5.7.5.3 Total Fenestration Product VT.....	20
	5.7.6 Testing.....	20
	5.7.6.1 Center-of-Glazing Component Test Procedure	20
	5.7.6.2 Total Fenestration Product Test Procedure.....	20
	5.7.6.3 Total Fenestration Product SHGC for Non-Model Sizes	21
	5.7.7 Figures.....	22
	Figure 5-1 Residential Fixed Aluminum Frame Reference Product	22
	Figure 5-2 Residential Fixed Wood Frame Reference Product	23
	Figure 5-3 Nonresidential Windowwall Aluminum Frame Reference Product	24
	Figure 5-4 Cross Section A.....	25
	Figure 5-5 Cross Section B.....	25
5.8	DYNAMIC ATTACHMENT FOR SWINGING DOORS	26
	5.8.1 Scope	26
	5.8.2 Methodology	26
	5.8.3 Approved Computational Program.....	26
6.	References.....	26
APPENDIX A	(Non-mandatory Information).....	27
Index	28

1. PURPOSE

To specify a method for calculating Solar Heat Gain Coefficient (SHGC) and Visible Transmittance (VT) at normal (perpendicular) incidence for fenestration products containing glazings or glazing with applied films, with specular optical properties calculated in accordance with ISO 15099 (except where noted) or tested in accordance with NFRC 201.

[*Note 1.*: This standard specifies a method for calculating the solar heat gain and visible transmittance from direct solar radiation through most fenestration products at normal incidence only. This procedure is limited to normal incidence calculations because solar optical data needed for such calculations is typically only available at normal incidence. While solar radiation rarely enters a fenestration product at normal incidence, solar heat gain coefficients and visible transmittance at near normal angles of incidence (less than 30 degrees off normal) are typically very similar to those at normal incidence; for other angles, the solar heat gain coefficients and visible transmittance at normal can be used, to first order, as an indicator of the relative magnitude of solar heat gain and visible transmittance.]

2. SCOPE

2.1 Products Covered

- A. Products of all frame materials including, but not limited to, aluminum, steel, thermally broken aluminum, wood, vinyl, reinforced vinyl, fiberglass, and plastic, used independently or in combination.
- B. Products of all operator or unit types including, but not limited to, vertical sliding windows, horizontal sliding windows, casement windows, projecting windows, fixed windows, non-standard shaped windows, glazed wall systems, glazings for site built fenestration products, bay or bow windows, and skylights.
- C. Single or multiple assemblies of exterior doors.
- D. Products of any size.
- E. Products of all glazing materials, tints, and types, including, but not limited to, clear glass, tinted glass, laminated glass, dynamic glazing product, thin plastic films (internally suspended, internally applied, or externally applied), rigid plastics with or without any solar control, low-E or any other partially transparent coating.
- F. Products with any or no gap width between glazing layers.

- G. Products with any gas-fill between glazing layers, including, but not limited to, air, argon, krypton, CO₂ or mixes of these gases.
- H. Products with any spacer or spacer systems between glazings, including, but not limited to, metallic, non-metallic or composite spacers.
- I. Products utilizing any and all glazing dividers, including, but not limited to, interior, exterior, or between glazing grilles, muntin bars, true divided lites or simulated divided lites.
- J. Products designed for installation at any tilt.
- K. “Film” attachment products which consist of a flexible adhesive-backed polymer film which may be applied to the interior or exterior surface of an existing glazing system in an installed fenestration product (i.e., as a retrofit, ‘field-installed’ or ‘daylight-installed’).

[**Note 2.**: Films factory-applied to glazing prior to fenestration product fabrication and installation are already covered as glazing options by NFRC 200 and shall not be rated according to the procedure of Section 5.7.]

Internal shading systems are included in 2.1.1A and shall be tested in accordance with NFRC 201.

2.1.1 Products Covered using NFRC 201 Test Procedure for SHGC

Products not covered by NFRC 200 simulation techniques and that are covered by test only procedures are as follows:

- A. Products with shading systems between the glazing layers of the fenestration aperture.
- B. Products with non-specular transmittance and reflectance properties, including, but not limited to, translucent fiberglass and glass blocks.
- C. Fenestration systems whose glazing departs from being parallel, such as with curved glazing, complete bay windows, corrugated or patterned glazing or glazing blocks. (Fenestration systems made up of combinations of complete windows or doors each of which individually meets the requirements in Section 2.1 can be included by treating each of the windows or doors separately.).
- D. Tubular daylighting devices.
- E. Garden or greenhouse windows.
- F. Adhesive-backed film products with non-specular transmittance and reflectance properties, including, but not limited to, opaque, textured, translucent or ‘frosted’ films.

- G. Adhesive-backed film products with non-uniform properties across their surface, including, but not limited to, patterned films.
- H. Dynamic Attachment Products for Swinging Doors

2.2 Products and Effects Not Covered

2.2.1 Products and Effects Not Covered (SHGC)

It is the intent of this procedure to add the following products to the scope once a solar heat gain test procedure and/or advanced calculation methods have been developed. This may be accomplished through the issuance of a technical interpretation, addendum, and/or by a revision to this document.

- A. Products with shading systems attached to the outside of the fenestration aperture.
- B. Garage doors with or without glazed areas.
- C. Solar heat gain performance changes of a fenestration product over the course of time, i.e., long-term energy performance.
- D. Fenestration systems with angular selectivity that is with optical properties, though specular on the small scale which produce emerging rays whose angle of transmittance is not equal to the angle of incidence, measured with respect to the normal to the plane of the fenestration aperture.
- E. Adhesive-backed film products with light redirecting properties, that is with optical properties which produce one or more transmitted beams where the direction of the transmitted beam is not equal to the incident direction, including, but not limited to, holographic or microstructured films.
- F. Adhesive-backed film products incorporating materials with optical properties that vary in response to ambient conditions (chromogenic), such as electrochromic, thermochromic and photochromic materials.

2.2.2 Products and Effects Not Covered (VT)

It is the intent of this procedure to add the following products to the scope once a visible transmittance test procedure and/or advanced calculation methods have been developed. This may be accomplished through the issuance of a technical interpretation, addendum, and/or by a revision to this document.

- A. Products with shading systems, either between the glazing or attached to the inside or outside of the fenestration aperture.
- B. Garage doors with or without glazed areas.

- C. Visible transmittance performance changes of a window over the course of time, i.e., long-term energy performance.
- D. Products with non-specular transmittance and reflectance properties such as translucent fiberglass and glass blocks.
- E. Fenestration systems whose glazings depart from being parallel, such as with curved glass, complete bay windows, corrugated or patterned glass, glass blocks, etc. (Fenestration systems made up of combinations of complete windows or doors each of which individually meet the requirements in Section 2.1 can be included by treating each of the windows or doors separately).
- F. Fenestration systems with angular selectivity, which is with optical properties, though specular on the small scale which produces emerging rays whose angle of transmittance is not equal to the angle of incidence, measured with respect to the normal to the plane of the fenestration aperture.
- G. Tubular Daylighting Devices.

3. DEFINITIONS

Definitions and terms are in accordance with definitions in NFRC 100, terms not specified in NFRC 100 have been selected to apply to the fenestration systems.

Fenestration product with attachment: the total fenestration product resulting when a fenestration attachment is combined with (i.e., installed on) a reference fenestration product in the manner recommended by the manufacturer.

Fenestration attachment: a device designed to be physically attached to, incorporated with or covering a product that has been or may be rated according to NFRC procedures.

Film: fenestration attachment products which consist of a flexible adhesive-backed polymer film which may be applied to the interior or exterior surface of an existing glazing system.

Interlayer: a layer of material acting as an adhesive between plies of glass which adds additional performance to the finished product, for example, impact resistance, solar control, acoustical insulation.

Laminated glass: an assembly consisting of two or more lites of glass, conforming to Specification C 1036 or C 1048 that are bonded together by interlayer material.

Lite: another term for a pane of glass used in a fenestration product. Frequently spelled 'lite' in industry literature to avoid confusion with “light”, as in “visible light”.

Reference fenestration product: the fenestration product that an attachment is combined with for the purposes of rating. A reference fenestration product comprises a reference glazing system and a reference frame with a specified construction.

Reference glazing system: the glazing system in the reference fenestration product.

Reference frame: the frame of the reference fenestration product. This may or may not correspond to an actual frame type available commercially. The reference frames used for this procedure are shown in Section 5.7.

Solar Heat Gain Coefficient (SHGC):

Solar Heat Gain Coefficient (SHGC): the ratio of the solar heat gain entering the space through the fenestration product to the incident solar radiation. Solar heat gain includes directly transmitted solar heat and that portion of the absorbed solar radiation which is then reradiated, conducted or convected into the space.

Frame Solar Heat Gain Coefficient (SHGC_f): the solar heat gain through all frame and sash members divided by the total incident solar radiation and the frame area, as defined in NFRC 100.

Divider Solar Heat Gain Coefficient (SHGC_d): the SHGC representative of the divider area, as defined in NFRC 100.

Edge-of-glazing Solar Heat Gain Coefficient (SHGC_e): the SHGC representative of the edge-of-glazing area, as defined in NFRC 100.

Edge-of-divider Solar Heat Gain Coefficient (SHGC_{de}): the SHGC representative of the edge-of-divider area, as defined in NFRC 100.

Center-of-glazing Solar Heat Gain Coefficient (SHGC_c): the SHGC representative of the center-of-glazing area, as defined in NFRC 100.

Total fenestration product Solar Heat Gain Coefficient (SHGC_t): the SHGC representative of the total fenestration product, as defined in Equation 4-3 of Section 4.7.

SHGC₀: the total fenestration product Solar Heat Gain Coefficient for a center-of-glazing Solar Heat Gain Coefficient of 0.0.

SHGC₁: the total fenestration product Solar Heat Gain Coefficient for a center-of-glazing Solar Heat Gain Coefficient of 1.0.

Frame absorptance: the fraction of solar radiation absorbed by the exterior frame surface.

Frame color: the color of the exterior frame surface exposed to solar radiation. See frame absorptance.

Visible Transmittance (VT):

Visible Transmittance (VT): the ratio of the visible light entering the space through the fenestration product to the incident visible light. The visible light entering a space is weighted by the photopic response of the eye (refer to NFRC 300).

Frame Visible Transmittance (VT_f): the visible light through all frame and sash members divided by the total incident visible light and the frame area (as defined in NFRC 100).

Divider Visible Transmittance (VT_d): the VT representative of the divider area, as defined in NFRC 100.

Edge-of-glazing Visible Transmittance (VT_e): the VT representative of the edge-of-glazing area, as defined in Section 3.6 of NFRC 100; the value equals the center-of-glazing VT.

Edge-of-divider Visible Transmittance (VT_{de}): the VT representative of the edge-of-divider area, as defined in NFRC 100; the value equals the center-of-glazing VT.

Center-of-glazing Visible Transmittance (VT_c): the VT representative of the center-of-glazing area, as defined in NFRC 100.

Total fenestration product Visible Transmittance (VT_t): the VT representative of the total fenestration product, as defined in Equation 4-4 of Section 04.7.

VT_o : the total fenestration product visible transmittance for a center-of-glazing visible transmittance of 0.0.

VT_1 : the total fenestration product visible transmittance for a center-of-glazing visible transmittance of 1.0.

4. GENERAL

4.1 Compliance

Fenestration product ratings shall be determined following the procedure outlined in Section 4.1 in accordance with the criteria specified in Sections 4.2 through 4.8 as modified by applicable portions of Section 5. This section presents and references methods for determining specific fenestration product heat transfer properties or quantities used in the determination of these properties.

4.1.1 Product Line Simulation and Testing

The total fenestration product Solar Heat Gain Coefficient (SHGC) and Visible Transmittance (VT) shall be evaluated in the position specified in NFRC 100 and in accordance with ISO 15099, using the fenestration product sizes as given in Table 4-3 of NFRC 100. Fenestration products shall be evaluated without screens, removable grilles, or any other applied devices. The items listed below are exceptions to ISO 15099 that are to be implemented in NFRC approved software/algorithms:

1) Section 7 (ISO 15099) on Shading Systems is currently excluded from NFRC procedures.

4.1.2 Testing Alternative

The component or total fenestration product SHGC shall be tested in accordance with NFRC 201.

The component or total fenestration product VT shall be tested once a test procedure has been approved.

4.2 Product Lines and Individual Products

4.2.1 Product Lines

Refer to Section 4.2.1 of NFRC 100 for the definition of a product line.

4.2.2 Individual Products

Refer to Section 4.2.2 of NFRC 100 for the definition of an individual product. For the purposes of this procedure only, variations in gap width, frame or sash color, and/or gas fill do not constitute different individual products.

4.2.3 Grouping of Products

- A. Identify product groupings within a product line with respect to frame differences. Refer to Section 4.2.4 and Section 5.2.4 of NFRC 100, for simplifications to a product line. Determine representative frame U-Factors for a group from the existing U-Factor matrix. Use the frame option with the highest frame and edge U-Factor for the lowest center-of-glazing U-Factor in the matrix. The frame SHGC is determined using this frame U-Factor (refer to Section 4.7) and applies to all glazing options in the product grouping, regardless of the number of glazing layers, gap thicknesses, gas fills, and spacer type.
- B. Within the frame groupings, identify divider groupings, if any (refer to Section 4.2 and Section 5.2.4 of NFRC 100 for simplifications to a product line). Assume a default divider U-Factor of $2.27 \text{ W/m}^2 \cdot ^\circ\text{C}$ ($0.40 \text{ Btu/h} \cdot \text{ft}^2 \cdot ^\circ\text{F}$) for all dividers, regardless of type of divider or size, including coming. The divider SHGC is determined using this divider U-Factor (refer to Section 4.7) and applies to all glazing options in the product grouping, regardless of the number of glazing layers, gap thicknesses, gas fills, and spacer type. Separate dividers into two categories: those less than 25.4 mm (1.00 in.) wide and those greater than or equal to 25.4 mm (1.00 in.) wide. Dividers greater than or equal to 25.4 mm (1.00 in.) are modeled at 38.0 mm (1.50 in.) and dividers less than 25.4 mm

(1.00 in.) are modeled at 19.00 mm (0.75 in.). Products with dividers in only a portion of the product are assumed to have dividers in the entire product. For caming, a default width of 8.0 mm (0.3 in.) is used. For default divider and caming patterns refer to Section 4.2.4 and Section 5.2.4 of NFRC 100.

- C. When rating Dynamic Glazing Products with shading systems between glazing layers, it shall be permitted to group combinations of shading systems and glazing layers. For purposes of determining SHGC, the shading system and glazing layers comprising each group leader shall be determined as follows.
 - i. Shading systems within a group shall vary only by color of the shading systems. The shading system used in the group leader shall be of the darkest color within the group. The darkest color shall be defined as that color with the lowest L^* value in the CIE $L^*a^*b^*$ color space, as described in Section 8 of CIE 15.

If multiple shading systems within the group have the same, lowest, L^* value, then any one of those shading systems shall be permitted to be used in the group leader.
 - ii. Glazing layers within a group, and the corresponding glazing layers used in the group leader, shall be determined in accordance with the representative glazing pane thicknesses rules of Table 4-1.

Note: It is intended that these same rules shall apply to determining VT ratings as well, when procedures for obtaining VT ratings for such products are approved and implemented.

4.3 Standard Conditions

This section presents procedures for determining total or component fenestration product Solar Heat Gain Coefficient and Visible Transmittance. For rating Solar Heat Gain Coefficient and Visible Transmittance of individual products at model sizes, follow Section 4.4.

4.3.1 Simulation

Approved solar optical data shall be used with the approved center-of-glazing software. NFRC approved solar optical data is listed in Reference 4.

The center-of-glazing Solar Heat Gain Coefficient ($SHGC_c$) shall be determined using the following conditions:

$$\begin{aligned} T_{in} &= 24^{\circ}\text{C} (75^{\circ}\text{F}) \\ T_{out} &= 32^{\circ}\text{C} (90^{\circ}\text{F}) \\ V &= 2.75 \text{ m/s} (6.15 \text{ mph}) \end{aligned}$$

$$\begin{aligned}
 T_{r,m,out} &= T_{out} \\
 T_{r,m,in} &= T_{in} \\
 I_s &= 783 \text{ W/m}^2 \text{ (248 Btu/h}\cdot\text{ft}^2\text{)}
 \end{aligned}$$

4.3.2 Testing

Specified testing conditions in this section shall be used to determine the SHGC of the individual fenestration products. See Section 4.6.1 for both the center-of-glazing and the total fenestration product.

4.3.3 Environmental Conditions during NFRC 201 Testing

- A. Average nominal inside air temperature shall be 24°C (75°F).
- B. Inside surface coefficient (as measured on a vertical CTS per Section 5.5.1 of NFRC 201) shall be 7.7 W/m²K ± 5% (1.4 Btu/h·ft²·°F ± 5%).
- C. The solar irradiance shall never be less than 680 W/m² (200 Btu/h·ft²).
- D. The incident angle of the direct solar irradiance shall be maintained at less than or equal to 5 degrees from normal to the plane of the solar calorimeter aperture (i.e., perpendicular to the outside surface of the surround panel); and
- E. The aperture of the solar calorimeter (i.e., the plane of the outside surface of the surround panel) shall not be tilted more than 60 degrees from vertical unless the laboratory can demonstrate that their calorimeter can meet the inside surface coefficient tolerance specified (Section 4.3.3.B) at the greater tilt angle.

4.3.3.1 Center-of-Glazing Component Test Procedure

The center-of-glazing SHGC shall be calculated in accordance with NFRC 201 applying environmental conditions specified in Section 4.3.3.

Guidance or the appropriate use of NFRC's approved procedure for Testing for Center-for-Glazing Component Test Procedure for center-of-glazing (VT_c) will be published as an addendum to this procedure or as a Technical Interpretation.

4.4 Model Sizes and Configurations

Total fenestration product Solar Heat Gain Coefficient and Visible Transmittance shall be determined for the model size shown in Table 4-3 of NFRC 100.

4.5 Simulation Procedures

This section presents the method for determining individual product SHGC and VT for model sizes.

Determine the total fenestration product SHGC and VT values for center-of-glazing SHGC and VT values of 0.0 and 1.0 per Section 4.7 for all applicable cases: no dividers, dividers less than 25.4 mm (1.00 in.) wide and greater than or equal to 25.4 mm (1.00 in.) wide, and caming when applicable.

- A. Nominal glass thickness may be used for determining the $SHGC_c$ and VT_c of the glazing system.
- B. Identify product groupings within a product line with respect to frame differences. Refer to Section 4.2 and Section 5.2.4 of NFRC 100, for simplifications to a product line. Determine representative frame U-Factors for a group from the existing U-Factor matrix. Use the frame option with the highest frame and edge U-Factor for the lowest center-of-glazing U-Factor in the matrix. The frame SHGC is determined using this frame U-Factor (refer to Section 4.7) and applies to all glazing options in the product grouping, regardless of the number of glazing layers, gap thicknesses, gas fills, and spacer type.
- C. Within the frame groupings, identify divider groupings, if any (refer to Section 4.2 and Section 5.2.4 of NFRC 100 for simplifications to a product line). Assume a default divider U-Factor of $2.27 \text{ W}/(\text{m}^2 \cdot ^\circ\text{C})$ ($0.40 \text{ Btu}/\text{h} \cdot \text{ft}^2 \cdot ^\circ\text{F}$) for all dividers, regardless of type of divider or size, including caming. The divider SHGC is determined using this divider U-Factor (refer to Section 4.6) and applies to all glazing options in the product grouping, regardless of the number of glazing layers, gap thicknesses, gas fills, and spacer type. Separate dividers into two categories: those less than 25.4 mm (1.00 in.) wide and those greater than or equal to 25.4 mm (1.00 in.) wide. Dividers greater than or equal to 25.4 mm (1.00 in.) are modeled at 38.0 mm (1.50 in.) and dividers less than 25.4 mm (1.00 in.) are modeled at 19.0 mm (0.75 in.). Products with dividers in only a portion of the product are assumed to have dividers in the entire product. The overall window dimension shall be used to determine the number of horizontal and vertical dividers. For caming, a default width of 8.0 mm (0.3 in.) used. For default divider and caming patterns refer to NFRC 100.

Tapes that are transparent or translucent shall be deemed to be equivalent the same glass without the tape.

- D. Determine the total fenestration product SHGC and VT values for center-of-glazing SHGC and VT values of 0.0 and 1.0 per Section 4.7 for all applicable cases: no dividers, dividers less than 25.4 mm (1.00 in.) wide and greater than or equal to 25.4 mm (1.00 in.) wide, and caming when applicable. Total fenestration product Solar Heat Gain

Coefficient and Visible Transmittance shall be determined for the model size shown in Table 4-3 of NFRC 100.

- E. For any $SHGC_c$, the total fenestration product SHGC can be calculated using the following equation:

$$SHGC = SHGC_0 + SHGC_c (SHGC_1 - SHGC_0) \quad \text{Equation 4-1}$$

Where

- $SHGC_0$ = the total fenestration product SHGC for the center-of-glazing SHGC of 0.0
 $SHGC_1$ = the total fenestration product SHGC for the center-of-glazing SHGC of 1.0.

Perform the calculations with $SHGC_c$, $SHGC_0$, and $SHGC_1$ values to three significant figures (0.XXX). Report the final SHGC value to two significant digits (0.XX).

- F. For any VT_c , the total fenestration product VT can be calculated using the following equation:

$$VT = VT_0 + VT_c (VT_1 - VT_0) \quad \text{Equation 4-2}$$

Where

- VT_0 = the total fenestration product VT for the center-of-glazing VT of 0.0 and
 VT_1 = the total fenestration product VT for the center-of-glazing VT of 1.0.

Perform the calculation with VT_c , VT_0 , and VT_1 values to three significant digits (0.XXX). Report the final VT value to two significant digits (0.XX).

- G. A matrix of center-of-glazing SHGC and VT glazing options specific to the product line shall be created for use in Equation 4-1 and Equation 4-2. This center-of-glazing matrix may include variations in number of glazing layers, glazing types (tints, laminated glass, etc.), and glazing coatings.

For each product line, products may be rated using either:

- i. the actual glazing infill assemblies pane thickness; actual laminated pane thickness is always an option that can be used for determining SHGC and VT or
- ii. applicable representative glazing infill pane thicknesses in Table 4-1 for the range of glazing infill pane thicknesses, for that product line.

For laminated glass, use only products with 0.764 mm (0.03 in.) interlayer thickness and two layers of 3 mm (1/8 in.) glass to represent any combination of glass thickness and interlayer thickness for glass panes with a total thickness less than or equal to 7.1 mm (9/32 in.). For laminated glass with panes having a total thickness greater than 7.1 mm (9/32 in.), use the actual assembly.

Ratings for products with obscured or wired glass and/or stained glass shall be deemed to be equivalent to the ratings for clear glass.

Table 4-1 Representative Glazing Pane Thicknesses

Range of Glazing Infill Pane Thicknesses Used in Product Line ¹	Represented by Size
mm (in.)	mm (in.)
$x < 2.0$ ($x < 5/64$)	Actual
$2.0 < x < 4.5$ ($5/64 < x < 11/64$)	3.0 (1/8)
$4.5 < x < 7.1$ ($11/64 < x < 9/32$)	6.0 (1/4)
$7.1 < x$ ($9/32 < x$)	Actual

- H. Products that meet the definition of a Dynamic Glazing Product shall be rated at their full ON and OFF or full OPEN and CLOSED positions. The manufacturer shall specify the appropriate procedure to use to achieve the stated positions. Rating procedures for the stated positions shall be the same as for non-Dynamic Glazing Products.

4.5.1 Component

4.5.1.1 Approved Center-of-Glazing Simulation Program

Approved center-of-glazing software shall be used to determine SHGC_c and VT_c. NFRC approved software is listed in Reference 4.

4.5.1.2 Approved 2-D Heat Transfer Simulation Program

Approved 2-D heat-transfer software shall be used. NFRC approved software is listed in Reference 4. Determination of frame U-Factors for calculating frame SHGC shall comply with the conditions of NFRC 100.

4.6 Test Procedures

If a product cannot be simulated in accordance with Section 4.5, the test procedures in this section shall be used to determine the SHGC of the individual fenestration products: Section 4.6.2 for the center-of-glazing and Section 4.6.1 for the total fenestration product. However, these test procedures

¹ Total pane thickness for laminated glass. For laminated pane less than or equal to 7.1 mm (9/32 in.) for modeling SHGC and VT, the simulator shall use 3 mm–0.764 mm–3 mm (1/8 in.–0.03 in.–1/8 in.) to be the representative laminated glass.

shall only be used for the reporting of SHGC and VT if the size conditions in Section 4.4 of NFRC 100 are met. The only time a product line shall contain tested total fenestration product SHGC is when an accredited simulation laboratory states in writing that it cannot simulate an individual product(s) to a reasonable accuracy by either using the computational procedure or using combination of computational and center-of glazing component test procedure. In addition, the written permission of NFRC is required for products not specifically addressed in this document.

4.6.1 Total Fenestration Product

The total fenestration product SHGC shall be calculated in accordance with NFRC 201 at the conditions specified in Section 4.C.ii. Guidance or the appropriate use of NFRC's approved procedure for Total Fenestration product Test Procedure for VT will be published as an addendum to this procedure or as a Technical Interpretation.

4.6.2 Component

The center-of-glazing SHGC shall be calculated in accordance with NFRC 201.

Guidance or the appropriate use of NFRC's approved procedure for Testing for Center-or-Glazing Component Test Procedure for Center-of-Glazing (VT_c) will be published as an addendum to this procedure or as a Technical Interpretation.

4.7 Total Fenestration Product Rating

The total fenestration product SHGC and VT shall be calculated as outlined below:

- A. Determine all of the following, as applicable:
 - i. Center-of-glazing SHGC and VT using the approved center-of-glazing computational program.
 - ii. Edge-of-glazing SHGC and VT, equal to the center-of-glazing SHGC and VT values respectively.
 - iii. Frame and divider SHGC's shall be calculated in accordance with ISO 15099 Section 4.2.2. The alternate approach in Section 8.6 (ISO 15099) shall not be used.

[*Note 3.*: Current research is aimed at assessing which method is more accurate; at some point in the future, this recommendation may be revised.]

Frame and divider SHGC shall be calculated with a default frame and divider absorptance of 0.3 for all products except window glazed wall, sloped glazing systems as defined in Table 4-1 of NFRC 100, curtain wall and store front as defined in Section 5.6 in NFRC 100. For these products use a default

frame and divider absorptance of 0.5. The frame and divider U-Factors shall be determined with the 2-D heat transfer computational program at the environmental conditions specified in NFRC 100, except as noted in Section 4.5.

- iv. Opaque frame and divider VT are equal to 0.0.
 - v. Divider edge-of-glazing SHGC and VT, equal to the center-of-glazing SHGC and VT values respectively.
 - vi. The component areas:
 - (a) Center-of-glazing area.
 - (b) Divider area.
 - (c) Edge-of-glazing area.
 - (d) Edge-of-divider area.
 - (e) Frame area.
 - (f) Projected fenestration product area.
- B. Perform the following calculations as shown in Equation 4-3 to determine SHGC:
- i. Multiply all fenestration component SHGC, the center-of-glazing, edge-of-glazing, divider, edge-of-divider, and frame SHGC by their corresponding areas.
 - ii. Total these quantities; and
 - iii. Divide this total by the projected fenestration product area to produce computed total fenestration product SHGC for all the fenestration products in the matrix of required SHGC (see Section 4.5).

$$SHGC = \frac{\left[(SHGC_f A_f) + (SHGC_d A_d) + (SHGC_e A_e) + (SHGC_{de} A_{de}) + (SHGC_c A_c) \right]}{A_{pf}}$$

Equation 4-3

Where

- $SHGC$ = Total product SHGC
- $SHGC_f$ = Frame SHGC-value
- A_f = Frame area, m² (ft²)
- $SHGC_d$ = Divider SHGC
- A_d = Divider area
- $SHGC_e$ = Edge-of-glazing SHGC
- A_e = Edge-of-glazing area
- $SHGC_{de}$ = Edge-of-divider SHGC
- A_{de} = Edge-of-divider area
- $SHGC_c$ = Center-of-glazing SHGC
- A_c = Center-of-glazing area
- A_{pf} = Projected fenestration product area

- C. Perform the following calculations as shown in Equation 4-4 to determine VT:
- i. Multiply all fenestration component VT, the center-of-glazing, edge-of-glazing, divider, edge-of-divider and frame VT by their corresponding areas.
 - ii. Total these quantities; and
 - iii. Divide this total by the projected fenestration product area to produce computed total fenestration product VT for all the fenestration products in the matrix of required VT (see Section 4.5).

$$VT = \frac{\left[(VT_f A_f) + (VT_d A_d) + (VT_e A_e) + (VT_{de} A_{de}) + (VT_c A_c) \right]}{A_{pf}}$$

Equation 4-4

Where

- VT = Total product VT
- VT_f = Frame VT-value
- A_f = Frame area
- VT_d = Divider VT
- A_d = Divider area
- VT_e = Edge-of-glazing VT
- A_e = Edge-of-glazing area
- VT_{de} = Edge-of-divider VT
- A_{de} = Edge-of-divider area
- VT_c = Center-of-glazing VT
- A_c = Center-of-glazing area
- A_{pf} = Projected fenestration product area

5. VARIATION FROM THE GENERAL REQUIREMENTS

5.1 Window and Sliding Glass Doors

No variation from Section 4.

5.2 Swing Doors

5.2.1 Calculation of Total Product Rating

When simulating SHGC for continuous single pane decorative lite (decorative lite includes glass and caming), the decorative lite glass shall be assumed to have the same properties as clear glass of the same glass thickness and each decorative lite caming pattern shall be considered to be a different individual product or the optional caming

pattern as shown in Table 5-1 and Table 5-2 may be used to represent all decorative lite coming patterns. The default coming profile may be used to represent any coming profile.

When simulating SHGC where a single pane decorative lite (continuous or non-continuous) is used as the middle layer of a triple glazed glass unit, the decorative lite glass shall be assumed to have the same properties as clear glass of the same glass thickness and each decorative lite coming pattern shall be considered to be a different individual option or the optional coming pattern as shown in Table 5-1 and Table 5-2 may be used to represent all decorative lite coming patterns. The default coming profile may be used to represent any coming profile.

5.2.1.1 Simplification

For U-factor simulation, if the minimum distances between the surrounding glass and the decorative lite, both glass and coming, are greater than 3 mm (0.118 in.):

- A. the coming pattern may be ignored and the option modeled as triple-glazed, or
- B. the decorative lite layer may be ignored and the option modeled as double-glazed.

For SHGC simulation, the double-glazed option shall be rated with the less than 25 mm (1 in.) divider option. For reporting purposes, this option shall not be grouped with any other option.

5.3 Skylights

5.4 Tubular Daylighting Devices

5.5 Garage (Vehicular Access) Doors

5.6 Site Built

5.7 Combination Fenestration Attachment Products:

5.7.1 Scope

This section presents additional details specific to combination fenestration attachment products.

This section presents and references methods for determining specific combination fenestration attachment products Solar Heat Gain Coefficient (SHGC) and Visible Transmittance (VT).

[*Note 4.*: Films factory-applied to glazing prior to fenestration product fabrication and installation are already covered as

glazing options by NFRC 200 and shall not be rated according to the procedure of Section 5.7.]

5.7.2 Variations from Standard Product Lines

5.7.3 Variations from Standard Individual Products

5.7.4 Variations from Standard Simulation and Test Conditions

5.7.4.1 Approved Center-of-Glazing Computational Program

Approved center-of-glazing software shall be used to determine $SHGC_c$ and VT_c .

NFRC approved solar optical data shall be used for the film installed on 3 mm (1/8 in.) clear glass, 6 mm (1/4 in.) clear glass and 6 mm (1/4 in.) grey glass. Any clear glass may be used that has a center-of-glazing $SHGC_c$ of 0.86 ± 0.02 when modeled in configuration A and D below without the film installed. Any clear glass may be used that has a center-of-glazing $SHGC_c$ of 0.82 ± 0.02 when modeled in configuration B and E below without the film installed. Any grey glass may be used that has a center-of-glazing $SHGC_c$ of 0.59 ± 0.02 when modeled in configuration C and F below without the film installed.

The following reference glazing systems shall be simulated with and without the film installed:

- A. Single 3 mm (1/8 in.) Clear.
- B. Single 6 mm (1/4 in.) Clear.
- C. Single 6 mm (1/4 in.) Grey.
- D. Double 3 mm (1/8 in.) Clear/3 mm (1/8 in.) Clear: 13 mm (0.5 in.) air gap.
- E. Double 6mm (1/4 in.) Clear/ 6 mm (1/4 in.) Clear: 7 mm (0.3 in.) air gap.
- F. Double 6 mm (1/4 in.) Grey/ 6mm (1/4 in.) Clear: 7.0 mm (0.3 in.) air gap.

The position (surface number) of the film when installed on the glazing system shall be documented (i.e., #1 to #4).

This will yield the following matrix:

Table 5-1 Center-of-Glazing Values SHGC_c and VT_c

Reference Glazing System	Without Film		With Film		
	SHGC _c	VT _c	Film Posn.	SHGC _c	VT _c
3 mm (1/8 in.) clear	0.859	0.899			
6 mm (1/4 in.) clear	0.816	0.884			
6 mm (1/4 in.) grey	0.576	0.444			
3 mm (1/8 in.) clear 3 mm (1/8 in.) clear	0.761	0.814			
6 mm (1/4 in.) clear 6 mm (1/4 in.) clear	0.702	0.786			
6mm (1/4 in.) grey 6 mm (1/4 in.) clear	0.454	0.395			

5.7.5 Calculation of Total Product Rating

The reference fenestration product and combination fenestration attachment product SHGC and VT shall be calculated as outlined below:

Table 5-2 Values of SHGC₀ and SHGC₁ and VT₀ and VT₁ for Reference Products

Operator Type	Reference Frame	Reference Glazing	SHGC ₀	SHGC ₁	VT ₀	VT ₁
Residential Fixed	Aluminum	All 3 mm (1/8 in.) options	0.011	0.830	0.000	0.819
	Wood/Vinyl	All 3mm (1/8 in.) options	0.003	0.822	0.000	0.819
Non-Residential Window wall	Aluminum	All 6 mm (1/4 in.) options	0.014	0.915	0.000	0.901

5.7.5.1 Reference Fenestration Products

The construction of reference fenestration products that shall be used are listed in Table 5-3 along with their pre-calculated SHGC₀/SHGC₁ and VT₀/VT₁ values. Calculate the total fenestration product SHGC and VT for each reference fenestration product and the corresponding combination fenestration attachment product according to Section 5.7.5.2 and Section 5.7.5.3 below. This will result in the following matrix for each film product, where SHGC and VT values for ‘no film’ refer to the reference fenestration product and values ‘with film’ refer to the combination fenestration attachment product:

Table 5-3 Values of SHGC and VT for Reference and Combination Fenestration Attachment Products

Reference Product			SHGC		VT	
Operator Type	Reference Frame	Reference Glazing	no film	with film	no film	with film
Residential Fixed	Aluminum	3 mm (1/8 in.) clear	0.71		0.74	
	Wood Vinyl	3 mm (1/8 in.) clear	0.71		0.74	
Non-Residential Windowwall	Aluminum	6 mm (1/4 in.) clear	0.75		0.80	
		6 mm (1/4 in.) grey	0.53		0.40	
Residential Fixed	Aluminum	3 mm (1/8 in.) clear	0.63		0.67	
		3 mm (1/8 in.) clear				
	Wood Vinyl	3 mm (1/8 in.) clear	0.63		0.67	
		3 mm (1/8 in.) clear				
Non-Residential Windowwall	Aluminum	6 mm (1/4 in.) clear	0.65		0.71	
		6 mm (1/4 in.) clear				
		6 mm (1/4 in.) grey	0.42		0.36	
		6 mm (1/4 in.) clear				

5.7.5.2 Total Fenestration Product SHGC

Calculate the total fenestration product SHGC for each reference fenestration product and the corresponding combination fenestration attachment product using the following equation:

$$SHGC = SHGC_0 + SHGC_c (SHGC_1 - SHGC_0) \quad \text{Equation 5-1}$$

Where

- $SHGC_0$ = the total fenestration product SHGC for the center-of-glazing SHGC of 0.0 from column 4 of Table 5-3.
- $SHGC_1$ = the total fenestration product SHGC for the center-of-glazing SHGC of 1.0 from column 5 of Table 5-3.
- $SHGC_c$ = the center-of-glazing SHGC for the reference glazing or the reference glazing with the film applied, from columns 2 and 5 of the center-of-glazing matrix generated according to Section 5.7.4.1 above.

Perform the calculations with $SHGC_c$, $SHGC_0$ and $SHGC_1$ values to three significant digits. Report the final SHGC value to two significant digits.

5.7.5.3 Total Fenestration Product VT

Calculate the total fenestration product VT for each reference fenestration product and the corresponding combination fenestration attachment product using the following equation:

$$VT = VT_0 + VT_c (VT_1 - VT_0) \quad \text{Equation 5-2}$$

Where

- VT_0 = the total fenestration product VT for the center-of-glazing VT of 0.0 from column 6 of Table 5-3
- VT_1 = the total fenestration product VT for the center-of-glazing VT of 1.0 from column 7 of Table 5-3
- VT_c = the center-of-glazing VT for the reference glazing or the reference glazing with the film applied, from columns 3 and 6 of the center-of-glazing matrix generated according to Section 5.7.4.1 above.

Perform the calculations with VT_c , VT_0 and VT_1 values to three significant digits. Report the final VT value to two significant digits.

5.7.6 Testing

If a combination fenestration attachment product cannot be simulated in accordance with Section 5.7.4.1, the center-of-glazing test procedure in Section 5.7 shall be used to determine the SHGC and VT of the reference fenestration product glazing system and combination fenestration attachment product glazing system. These values shall be used to calculate the total product SHGC and VT according to Section 5.7.5 above.

5.7.6.1 Center-of-Glazing Component Test Procedure

The center-of-glazing component SHGC ($SHGC_c$) shall be tested in accordance with NFRC 201 – see Section 7.2.2.1 of NFRC 201 for details on how to install a center-of-glazing specimen for testing.

Guidance for the appropriate use of NFRC’s approved procedure for Center-of-Glazing Component Test Procedure (VT_c) will be published as an addendum to this procedure or as a Technical Interpretation.

5.7.6.2 Total Fenestration Product Test Procedure

Not applicable – the frame and edge-of-glazing SHGC and VT values of reference fenestration products must be simulated.

5.7.6.3 Total Fenestration Product SHGC for Non-Model Sizes

Not applicable – all reference fenestration products and combination fenestration attachment products are to be at model sizes.

5.7.7 Figures

Figure 5-1 Residential Fixed Aluminum Frame Reference Product

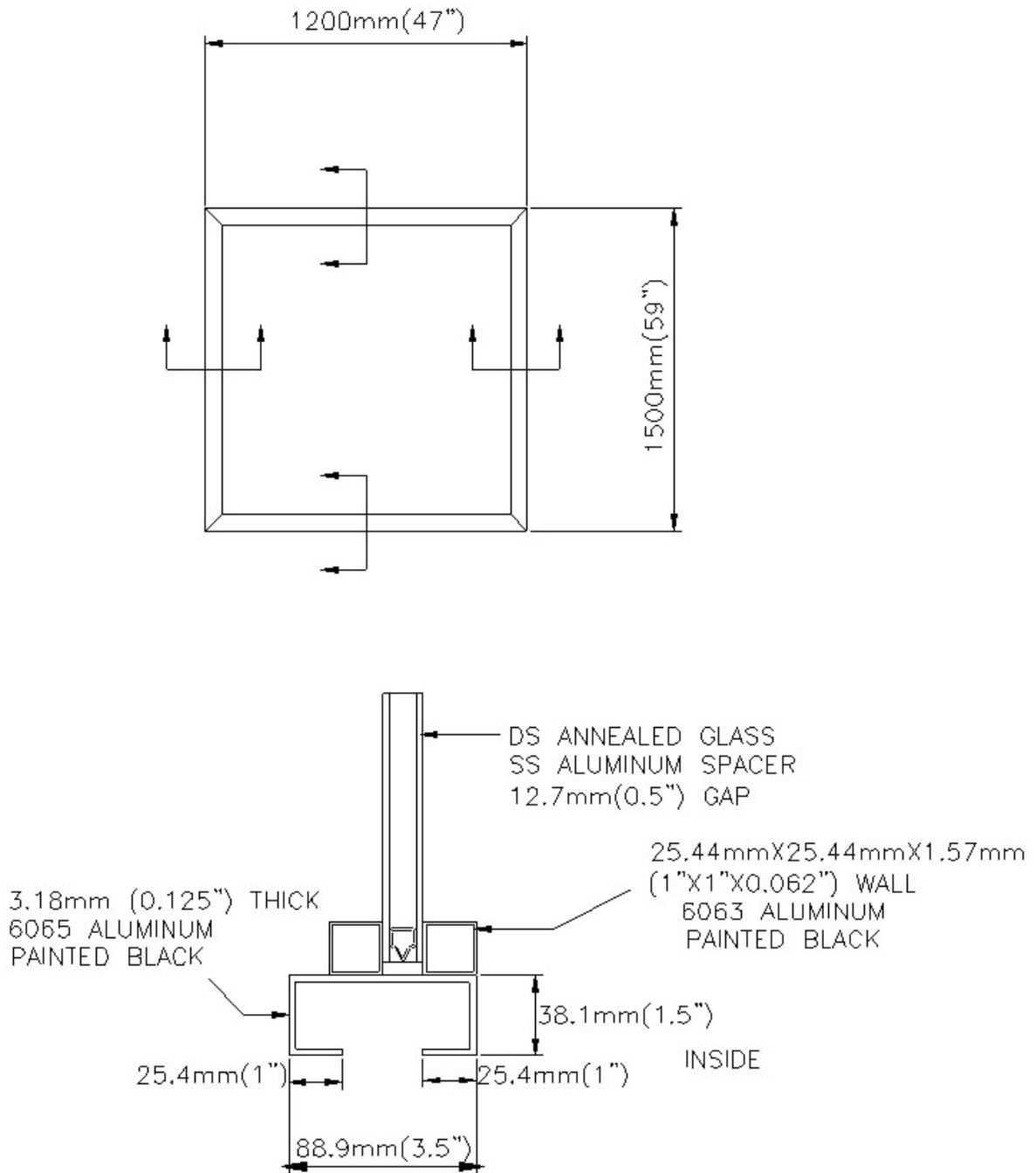

Figure 5-2 Residential Fixed Wood Frame Reference Product

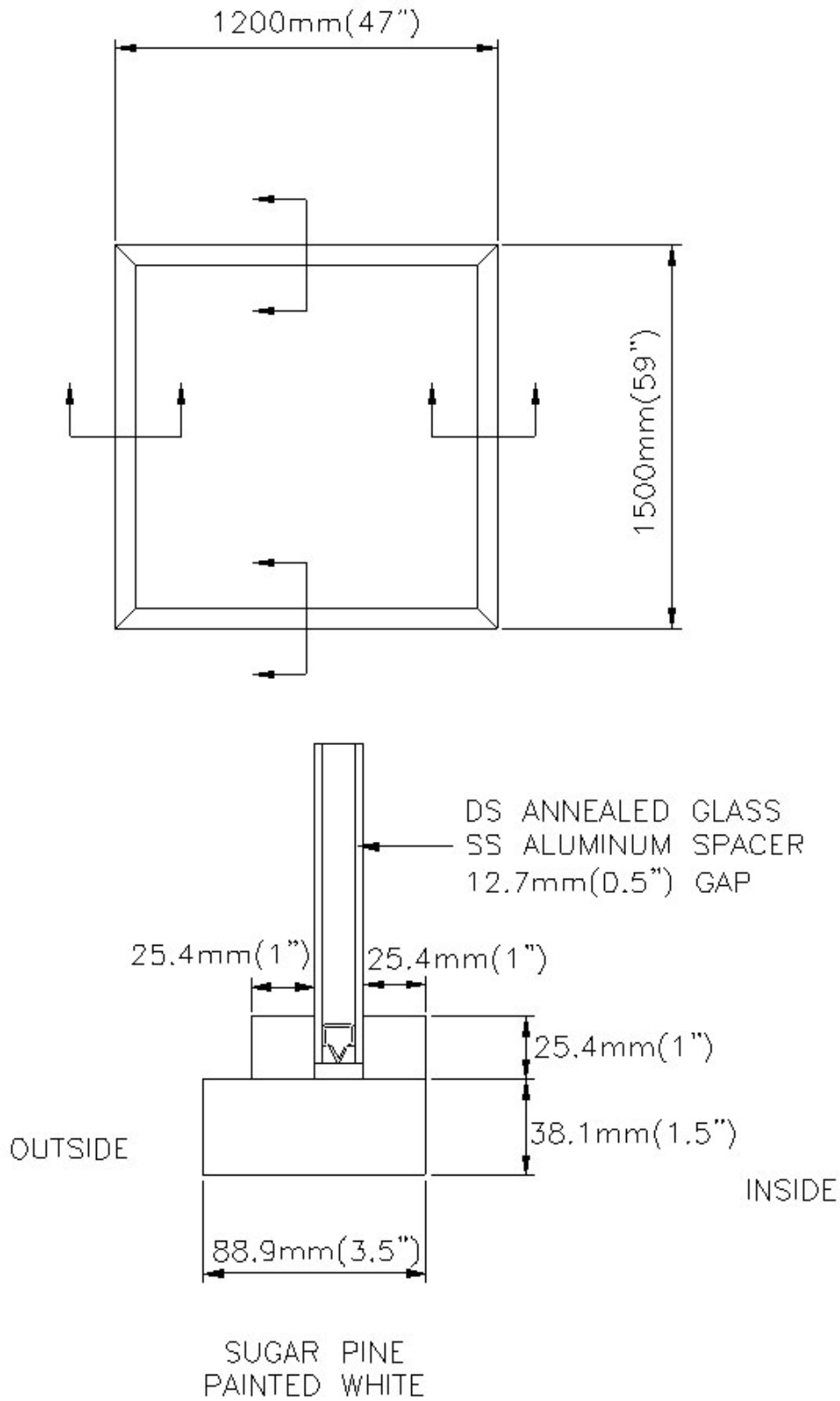

Figure 5-3 Nonresidential Windowwall Aluminum Frame Reference Product

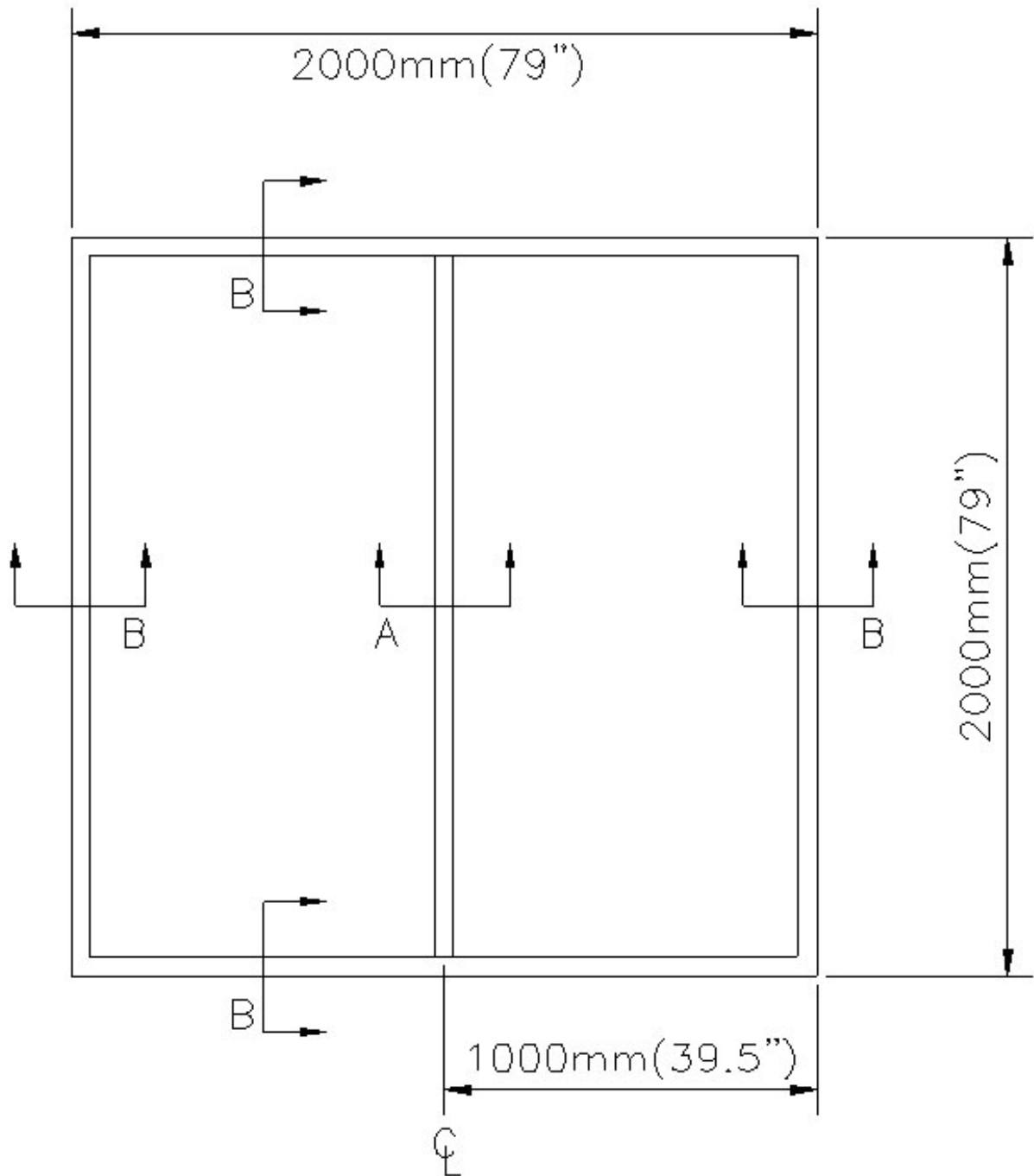

Figure 5-4 Cross Section A

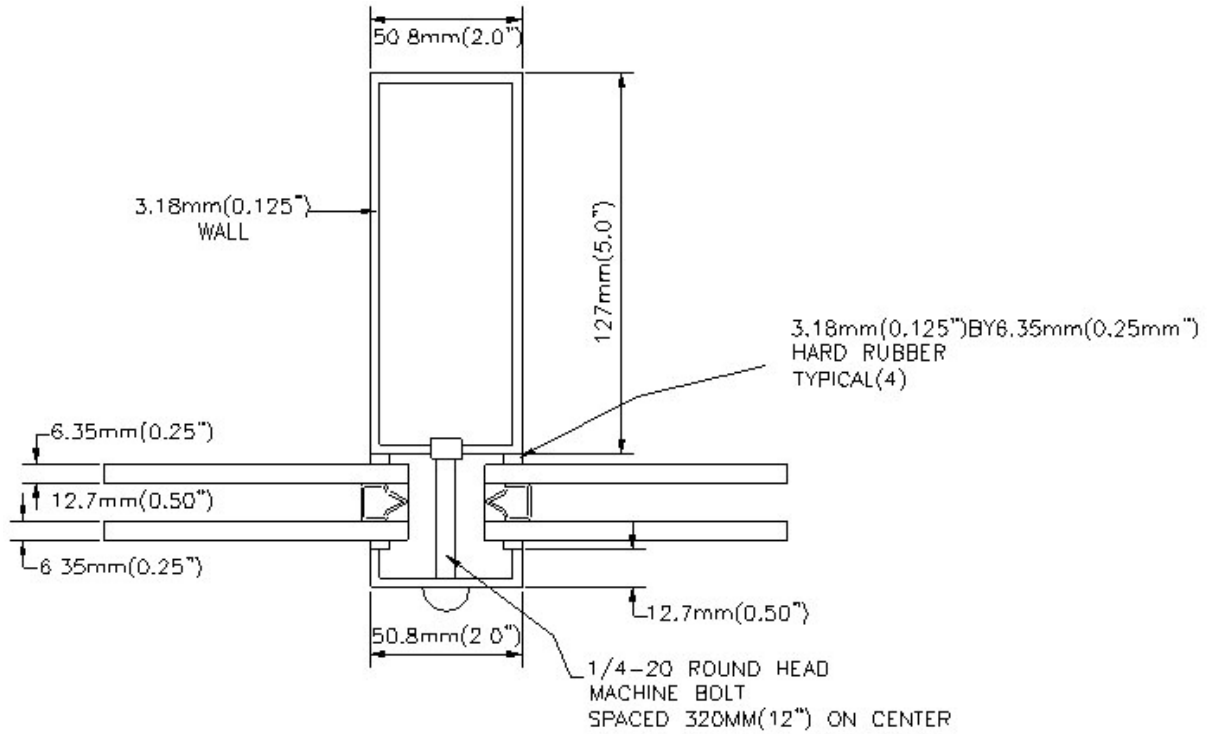
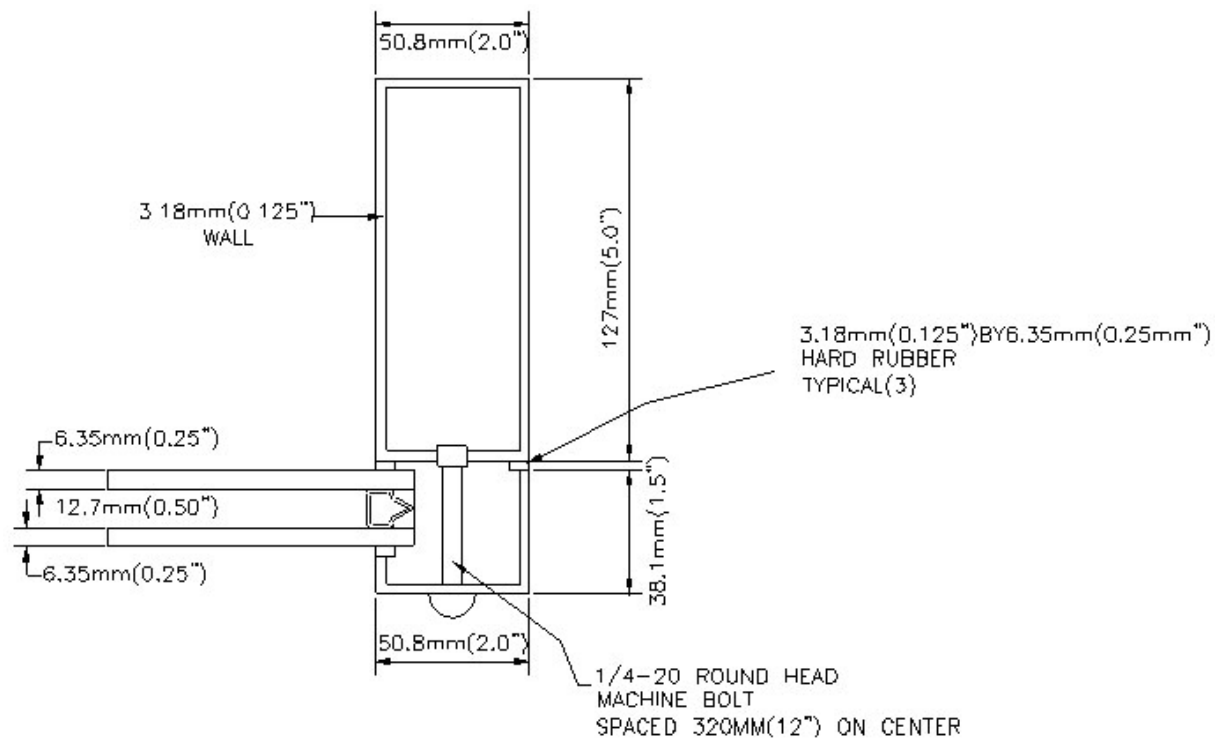

Figure 5-5 Cross Section B



5.8 Dynamic Attachment Products for Swinging Doors

Rating procedures for full glazed swinging doors shall be used with the dynamic attachment in the “fully open” and “fully closed” position.

5.8.1 Scope

This section presents additional details specific to Dynamic Attachments for Swinging Doors. This section presents and references methods for determining specific Dynamic Attachments for Swinging Doors Solar Heat Gain Coefficient (SHGC) and Visible Transmittance (VT).

5.8.2 Methodology

Methodology for rating Full Light Swinging Doors can be found in Section 5.2. Dynamic Attachment for Swinging Door products will be rated using reference Swinging Doors outlined in NFRC 100 Section 5.7.

5.8.3 Approved Computational Program

The Dynamic Attachment for Swinging Door Product’s Solar Heat Gain Coefficient and Visual Transmittance shall be determined using approved glazed swinging door simulation. The Dynamic Attachment for Swinging Door shall be modeled on the reference swinging doors indicated in NFRC 100 Section 5.7.3.

6. REFERENCES

- [1] National Fenestration Rating Council. NFRC 100-2004: Procedure for Determining Fenestration Product U-Factors, Silver Spring, MD.
- [2] National Fenestration Rating Council. NFRC 300-2004: Test Method for Determining the Solar Optical Properties of Glazing Materials and Systems, Silver Spring, MD.
- [3] National Fenestration Rating Council. Simulation Manual-2004: Silver Spring, MD.
- [4] National Fenestration Rating Council. List of Approved Simulation Programs. Silver Spring, MD.
- [5] ISO 15099 : Thermal Performance of Windows, Doors and Shading Devices — Detailed Calculations
- [6] ASTM C 1172-03: Standard Specification for Laminated Architectural Flat Glass
- [7] ASTM C 1036-01: Standard Specification for Flat Glass

- [8] ASTM C 1048-04: Standard Specification for Heat-Treated Flat Glass—Kind HS, Kind FT Coated and Uncoated Glass
- [9] CIE 15:2004, 3rd Edition: Technical Report – Colorimetry

APPENDIX A (NON-MANDATORY INFORMATION)

Determination of SHGC and VT at Non-Standard Sizes

The approved total fenestration product SHGC and VT calculation procedure may be used to evaluate the total fenestration product SHGC and VT for size configurations other than the Model Sizes for purposes other than certification.

INDEX

C

C 1036..... 4, 13, 26
C 1048..... 4, 27
CTS 9

F

Fenestration Attachment 4, 16, 19
Fenestration product with attachment..... 4
Film..... 2, 4, 18
Frame absorptance 5
Frame color 5

I

Interlayer 4
ISO 15099 ii, 1, 6, 7, 13, 26

L

Laminated glass 4
Lite 4

N

NFRC 100.. 4, 5, 6, 7, 9, 10, 11, 12, 13, 26
 Section 3.6..... 6
 Section 4.2..... 7, 8, 10, 13
 Section 4.2.4..... 7
 Section 4.4..... 8, 13
 Section 4.5..... 12, 14, 15

 Section 5.2.4..... 7, 8, 10
 Table 4-3 6, 9, 11
NFRC 201 ii, 1, 2, 7, 9, 13, 20
 Section 4.C.ii..... 13
 Section 5.5.1..... 9
 Section 7.2.2.1..... 20
NFRC 300 5, 26

R

Reference fenestration product 5
Reference frame 5
Reference Frame 18, 19
Reference glazing system 5

S

solar calorimeter..... 9
Solar Heat Gain Coefficient.... 1, 5, 6, 8, 9,
 11, 16

T

Testing Alternative..... 7

V

Visible Transmittance .. 1, 5, 6, 8, 9, 11, 16
VT₁..... 6
VT₀..... 6