



National Fenestration Rating Council Incorporated

NFRC 102-2010_[E0A2]

Procedure for
Measuring the Steady-State Thermal Transmittance
of Fenestration Systems

© 2010 NATIONAL FENESTRATION RATING COUNCIL, INC.

PREPARED BY:

National Fenestration Rating Council
6305 Ivy Lane, Suite 140
Greenbelt, MD 20770
Voice: (301) 589-1776
Fax: (301) 589-3884
Email: info@nfr.org
Website: www.nfr.org



FOREWORD

The National Fenestration Rating Council, Incorporated (NFRC) develops and operates a uniform rating system for energy and energy-related performance of fenestration and fenestration attachment products. The Rating System determines the U-factor, Solar Heat Gain Coefficient (SHGC), and Visible Transmittance (VT) of a product, which are mandatory ratings for labeling NFRC-certified products, and are mandatory ratings for inclusion on label certificates, and are supplemented by procedures for voluntary ratings of products for Air Leakage (AL) and Condensation Resistance. Together these rating procedures, as set forth in documents published by NFRC, are known as the NFRC Rating System.

The NFRC Rating System employs computer simulation and physical testing by NFRC-accredited laboratories to establish energy and related performance ratings for fenestration and fenestration attachment product types. The NFRC Rating System is reinforced by a certification program under which NFRC-licensed responsible parties claiming NFRC product certification shall label and certify fenestration and fenestration attachment products to indicate those energy and related performance ratings, provided the ratings are authorized for certification by an NFRC-licensed Certification and Inspection Agency (IA).

The requirements of the rating, certification, and labeling programs (Certification Programs) are set forth in the most recent versions of the following as amended, updated, or interpreted from time to time:

- NFRC 700 Product Certification Program (PCP)
- NFRC 705 Component Modeling Approach (CMA) Product Certification Program (CMA-PCP)

and through the Certification Programs and the most recent versions of its companion programs as amended, updated, or interpreted from time to time:

- The laboratory accreditation program (Accreditation Program), as set forth in the NFRC 701 Laboratory Accreditation Program (LAP)
- The IA licensing program (IA Program), as set forth in NFRC 702 Certification Agency Program (CAP)
- The CMA Approved Calculation Entity (ACE) licensing program (ACE Program) as

set forth in the NFRC 708 Calculation Entity Approval Program (CEAP)

NFRC intends to ensure the integrity and uniformity of NFRC ratings, certification, and labeling by ensuring that responsible parties, testing and simulation laboratories, and IAs adhere to strict NFRC requirements.

In order to participate in the Certification Programs, a Manufacturer/Responsible Party shall rate a product whose energy and energy-related performance characteristics are to be certified in accordance with mandatory NFRC rating procedures. At present, a Manufacturer/Responsible Party may elect to rate products for U-factor, SHGC, VT, AL, condensation resistance, or any other procedure adopted by NFRC, and to include those ratings on the NFRC temporary label affixed to its products or on the NFRC Label Certificate. U-factor, SHGC and VT, AL, and condensation resistance rating reports shall be obtained from a laboratory that has been accredited by NFRC in accordance with the requirements of the NFRC 701.

The rating shall then be reviewed by an IA that has been licensed by NFRC in accordance with the requirements of the NFRC 702. NFRC-licensed IAs review label format and content, conduct in-plant inspections for quality assurance in accordance with the requirements of the NFRC 702, and issue a product Certification Authorization Report (CAR) and may approve for issuance an NFRC Label Certificate for site-built or CMA products and attachment products. The IA is also responsible for the investigation of potential violations (prohibited activities) as set forth in the NFRC 707 Compliance and Monitoring Program (CAMP).

Products that are labeled with the NFRC Temporary and Permanent Label, or products that are listed on an NFRC Label Certificate in accordance with NFRC requirements, are considered to be NFRC-certified. NFRC maintains a Certified Products Directory (CPD), listing product lines and individual products selected by the Manufacturer/Responsible Party for which certification authorization has been granted.

NFRC manages the Rating System and regulates the PCP, LAP, and CAP in accordance with the NFRC 700 (PCP), the NFRC 701 (LAP), the NFRC 702 (CAP), the NFRC 705 (CMA-PCP), and the NFRC 708 (CEAP) procedures, and conducts compliance activities under all these programs as well as the NFRC 707 (CAMP). NFRC continues to develop the Rating System and each of the programs.

NFRC owns all rights in and to each of the NFRC 700, NFRC 701, NFRC 702, NFRC 705, NFRC 707, NFRC 708 and each procedure, which is a component of the Rating System, as well as each of its registration marks, trade names, and other intellectual property.

The structure of the NFRC programs and relationships among participants are shown in Figure 1, Figure 2, and Figure 3. For additional information on the roles of the IAs and laboratories and operation of the IA Program and Accreditation Program, see the NFRC 700 (PCP), NFRC 701 (LAP), and NFRC 702 (CAP) respectively.

Figure 1

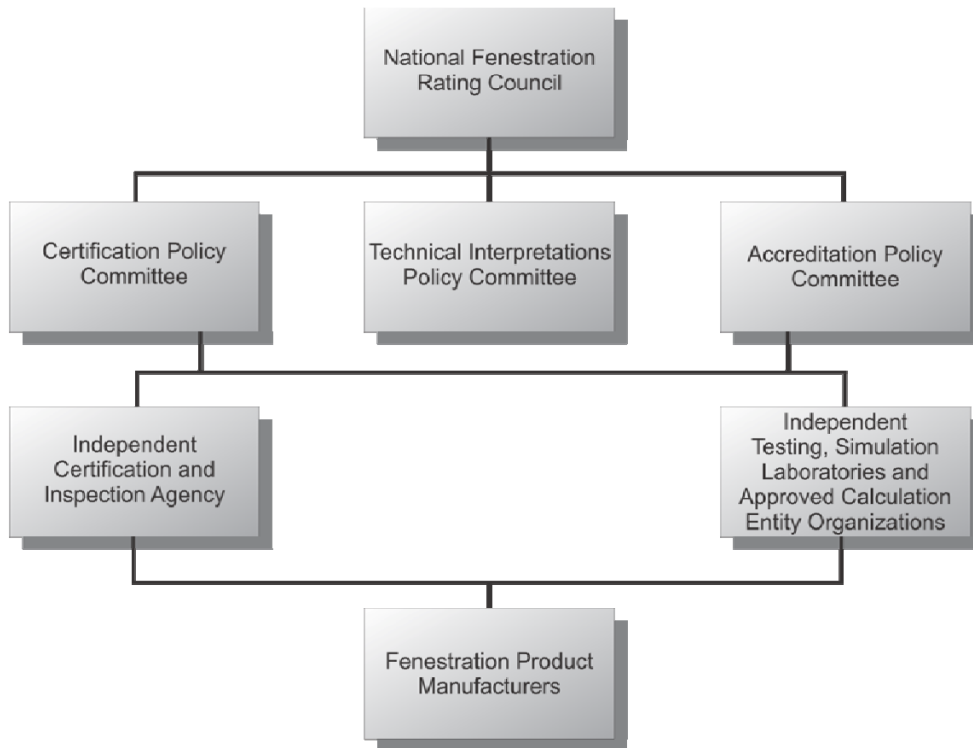

Figure 2

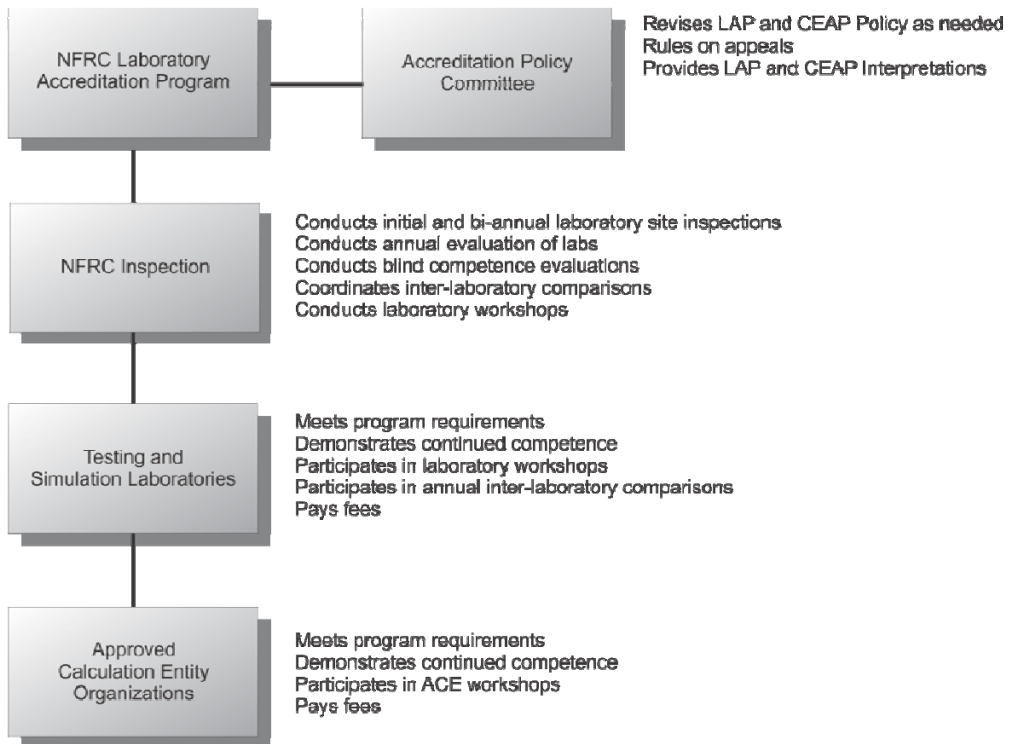
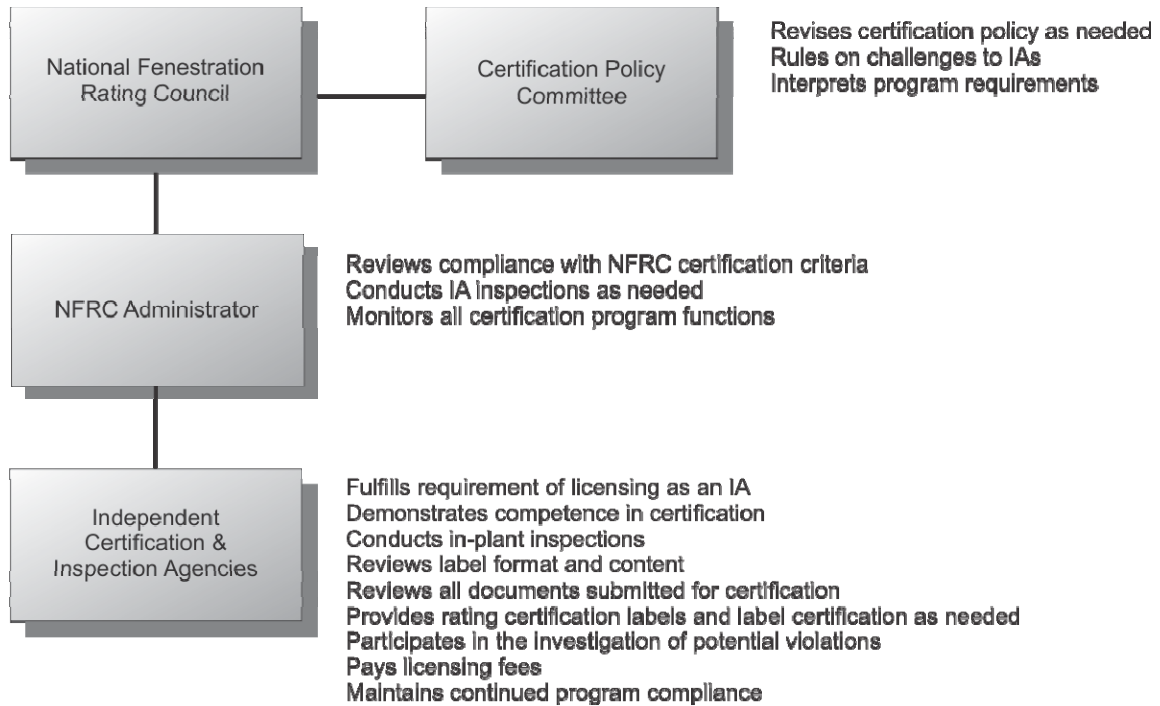

Figure 3



Questions on the use of this procedure should be addressed to:

National Fenestration Rating Council

6305 Ivy Lane, Suite 140
Greenbelt, MD 20770
Voice: (301) 589-1776
Fax: (301) 589-3884
Email: info@nfrc.org
Website: www.nfrc.org



DISCLAIMER

NFRC certification is the authorized act of a Manufacturer/Responsible Party in: (a) labeling a fenestration or related attachment product with an NFRC Permanent Label and NFRC Temporary Label, or (b) generating a site built or CMA label certificate, either of which bears one or more energy-related performance ratings reported by NFRC-accredited simulation and testing laboratories and authorized for certification by an NFRC-licensed IA. Each of these participants acts independently to report, authorize certification, and certify the energy-related ratings of fenestration and related attachment products.

NFRC does not certify a product and certification does not constitute a warranty of NFRC regarding any characteristic of a fenestration or fenestration-related attachment product. Certification is not an endorsement of or recommendation for any product or product line or any attribute of a product or product line. NFRC is not a merchant in the business of selling fenestration products or fenestration-related products, and therefore cannot warrant products as to their merchantability or fitness for a particular use.

NFRC THEREFORE DISCLAIMS ANY AND ALL LIABILITY THAT MAY ARISE FROM OR IN CONNECTION WITH SERVICES PROVIDED BY, DECISIONS MADE BY OR REPORTS OR CERTIFICATIONS ISSUED OR GRANTED BY ANY NFRC-ACCREDITED LABORATORY, NFRC-LICENSED IA OR ANY PRODUCT MANUFACTURER/ RESPONSIBLE PARTY; RELIANCE ON ANY NFRC PRODUCT DESCRIPTION, SPECIFICATION, RATING, TEST OR CERTIFICATION, WHETHER APPEARING IN A REPORT, A PRODUCT CERTIFICATION AUTHORIZATION OR A PRINTED OR ELECTRONIC DIRECTORY, OR ON A LABEL, OR ON A LABEL CERTIFICATE; OR THE SALE OR USE OF ANY NFRC-RATED OR CERTIFIED PRODUCT OR PRODUCT LINE; INCLUDING BUT NOT LIMITED TO DAMAGES FOR PERSONAL OR OTHER INJURY, LOST PROFITS, LOST SAVINGS OR OTHER CONSEQUENTIAL OR INCIDENTAL DAMAGES.

NFRC program participants are required to indemnify NFRC from and against such liability.



Table of Contents

FOREWORD	ii
DISCLAIMER	vi
1. Scope	1
2. Referenced Documents	1
3. Terminology	1
4. Significance and Use	1
5. Apparatus	1
6. Calibration	2
7. Experimental Procedure	6
8. Calculation of Thermal Transmittance	8
9. Calculation of Standardized Thermal Transmittance	8
10. Report	9
11. Precision and Bias	9
Annexes (Mandatory Information)	9
ANNEX A3. STANDARD TEST METHOD FOR DETERMINING THE THERMAL TRANSMITTANCE OF TUBULAR DAYLIGHTING DEVICES	10
ANNEX A4. GARAGE PANEL AND ROLLING DOOR INSTALLATION	22
ANNEX A5. TABLES AND FIGURES	23
Bibliography	35
Index	36

1. SCOPE

The following parts of Section 1: Scope of ASTM C1199-09 are valid for this procedure:

All

2. REFERENCED DOCUMENTS

The following parts of Section 2: Referenced Documents of ASTM C1199-09 are valid for this procedure:

All

3. TERMINOLOGY

The following parts of Section 3: Terminology of ASTM C1199-09 are valid for this procedure:

All

4. SIGNIFICANCE AND USE

Section 4: Significance and Use of ASTM C1199-09 is to be considered non-mandatory information.

5. APPARATUS

The following parts of Section 5: Apparatus of ASTM C1199-09 are valid for this procedure:

All, with additions noted below

The following parts of Section 5: Apparatus of ASTM C1199-09 are amended for this procedure:

5.1.3.2 is valid in its entirety with the following addition:

For garage and rolling doors, specimens shall be sealed so as to anticipate movement of the specimen due to thermal stresses. These specimens shall be sealed at both the interior and exterior surfaces.

6. CALIBRATION

The following parts of Section 6: Calibration of ASTM C1199-09 are valid for this procedure:

All, with additions noted below.

The following parts of Section 6: Calibration of ASTM C1199-09 are amended for this procedure:

6.1 is valid in its entirety with the following addition of 6.1 (A)

6.1 (A) Calibrations shall be completed at a minimum frequency in accordance with the list in this section.

1. **Required Calibration - Primary Measurement Equipment**

All calibrations shall be performed either in-house or by an ISO 17025 accredited calibration laboratory. If in-house calibrations are performed, the calibration equipment shall be calibrated annually by an ISO 17025 accredited calibration laboratory.

Table 6-1 – Calibrations Required

<u>Calibrations Required</u>	<u>Frequency</u>
Power Measurement Equipment	Annual
Thermocouples	Annual
Relative Humidity Sensor	Annual
Interior Wind Velocity Sensors	None -- Monitoring device only. Calibration of interior film coefficient dictates proper natural convection. Alternative methods of monitoring velocity shall be allowed if properly documented by the laboratory.
Exterior Wind Velocity Sensors	None -- Monitoring device only. Calibration of exterior film coefficient dictates velocity. Alternative methods of monitoring velocity shall be allowed if properly documented by the laboratory.
Exterior Wind Velocity Mapping	Once and done if the fan speed is monitored. Mapping is required if any change in the location of the fans relative to the surround panel or if any change is made in the fan speed or any turning vanes or baffles.

<u>Calibrations Required</u>	<u>Frequency</u>
Flanking Loss	Once and done, but verified on a continuing basis. Flanking loss is inclusive in the metering box characterization of ASTM C1199, Section 6. 1. Flanking loss verification is inclusive in the continuing metering box wall verification.
Surround Panel/Characterization Panel Apparent Thermal Conductance Characterization	Once and done.
CTS Core Apparent Thermal Conductance Characterization	Once and done.
CTS Calibration (Surface Coefficients)	Once and done, but verified continuously. Recalibration is required if interval testing drifts out of acceptable limits. Drift cannot be more than 5% from previous calibration for both the exterior and interior film coefficients.
Metering Box Wall Transducer and Surround Panel Flanking Loss Characterization	Once and done, but verified annually.

2. **Metering Box Wall Transducer and Surround Panel Flanking Loss Characterization and Annual Verification Procedure**

For purposes of this section, a surround panel is a panel constructed for use during testing which may or may not have an opening cut into it. If there is an opening in the panel, the opening shall be filled with core material from the same lot as the panel with the same thickness as the core. A characterization panel is a panel constructed identically to the surround panels from the same lot(s) as the surround panel which does not have a hole cut from it and is maintained solely for characterization of the specific panel lot and thickness. If characterization panels are used, there shall be one for each wall thickness and core material lot used for the surround panels.

Metering box walls and flanking loss ($m^*E + E_o + Q_{fl}$) shall be characterized in accordance with ASTM C1199, Section 6.1.1.1 prior to initial use of the chamber. The laboratory shall maintain characterization records for each panel for comparison purposes.

At least one surround panel (or a characterization panel) shall be characterized annually. If all panels were not characterized during the initial characterization process, use a panel that has not been characterized until all panels are characterized. If all panels are characterized then verify a previously characterized panel. The results from a previously verified panel shall not deviate more than 2 watts (7 Btu/hr) from the first result. If three or more results are available for any one panel the difference between any two results shall not be more than 2 watts (7 BTU/Hr) and all readings shall be monitored for trending. If the results deviate by more than 2 watts (7 BTU/Hr) the metering box shall be re-characterized in accordance with ASTM C1199, Section 6.1.1.1.

As an additional check the smallest CTSs shall be tested in the thickest wall and the resulting Q_s as calculated using equations (1) or (2) compared to Equation (1A, 2A) shall not vary by more than 10%.

3. **CTS Calibration (Surface Coefficients) Continuous Characterization Procedure**

CTS panels shall be tested in the thinnest surround panel used in a given metering room. A large and small CTS panel shall be selected for each metering room based on the largest and smallest test samples to be tested in that metering room.

Consideration of height and overall area should be given when selecting the CTS panels, as height of the panel will have a stronger influence than overall area on the film coefficients.

All required CTS calibrations shall be performed prior to initial use of the metering box. Thereafter, the laboratory shall test CTSs at regular intervals close enough to each other that all CTS/metering room combinations are tested at least once every two years. So long as the calculated room- and weather-side surface coefficients remain within tolerance, and the Q_s calculated using equations (1) or (2) compared to Equation (1A, 2A) does not vary by more than 10%, the chamber shall be considered to be in calibration. During these verification tests no adjustments shall be allowed.

If the results are out of tolerance the chamber is no longer in calibration and the laboratory shall make the necessary adjustments to bring the surface coefficients within tolerance. If

adjustments are made, the laboratory shall verify that the remaining CTS results remain in tolerance.

4. **An Example Test Plan Based on Numbers 1 through 3 (above)**
One chamber with three metering boxes (4080, 6080, 8080) and five surround panel thicknesses of 100 mm, 125 mm, 150 mm, 175 mm, and 200 mm (4 in, 5 in, 6 in, 7 in, 8 in):

Table 6-2 - Initial Calibrations (Required) for Metering Box Wall/Surround Panel

<u>Metering Box</u>	<u>SP Thickness</u>	<u>EMF</u>
4080	100 mm (4 in)	Positive, 0, Negative
4080	200 mm (8 in)	Positive, 0, Negative
6080	100 mm (4 in)	Positive, 0, Negative
6080	200 mm (8 in)	Positive, 0, Negative
8080	100 mm (4 in)	Positive, 0, Negative
8080	200 mm (8 in)	Positive, 0, Negative

Optionally, based on the results of the above tests, the 125 mm (5 in), 150 mm (6 in), 175 mm (7 in) surround panel may be tested if 100 mm (4 in) and 200 mm (8 in) results indicate a need.

Table 6-3 - Continuing Calibrations (Required) for Metering Box Wall/Surround Panel

<u>Metering Box</u>	<u>SP Thickness</u>	<u>EMF</u>
4080	*125mm (5 in)	Positive, 0, Negative

(*This was selected since it was previously an uncharacterized panel)

Table 6-4 - Initial Calibrations (Required) for CTS Panels

<u>Metering Box</u>	<u>SP Thickness</u>	<u>CTS Panel</u>
4080	100 mm (4 in)	Small
4080	100 mm (4 in)	Large
6080	100 mm (4 in)	Small
6080	100 mm (4 in)	Large
8080	100 mm (4 in)	Small
8080	100 mm (4 in)	Large

Continuing Calibrations (Required) for CTS Panels

All CTSs above shall be repeated within a two-year time frame.

6.1.2.2 is valid in its entirety with the following addition:

NFRC Steady State conditions may also be determined as follows:

1. Determining steady-state involves two separate evaluations. First, a series of four hourly sets of data are compared to the group mean to determine if steady state has been achieved. Second, two additional consecutive two-hour test periods are individually compared to the average initial four-hour period and each other to verify steady-state conditions are maintained. The following tests are applied to both assessments.
2. The average room and weather side air temperatures and all other surface temperatures shall not vary by more than $\pm 0.3^{\circ}\text{C}$ ($\pm 0.5^{\circ}\text{F}$) over the entire eight (8) hour steady state period. (See ASTM C1363 requirements.)
3. The total heat input into the metering box, Q (including Q_{mb} , Q_{fl} , and warm room heater and circulating fan power) shall be used to determine steady state. The mean of the four one-hour steady state periods shall agree within $\pm 1\%$ of the mean of each of the two hour test periods and each of the two (2) two-hour test periods must be within $\pm 1\%$ of one another.
4. As an alternative, steady-state conditions and time constant may be determined per ASTM C1363.

6.1.3.2 is valid in its entirety with the following addition:

As a secondary check on Q_s , the following equation is required:

$$Q_s = Q - Q_{sp} - Q_{fl} \quad (1A,2A)$$

This equation shall produce the same result as the equation (1) or (2) within $\pm 10\%$

7. EXPERIMENTAL PROCEDURE

The following parts of Section 7: Experimental Procedure of ASTM C1199-09 are valid for this procedure:

All except 7.5.2.1, 7.5.2.2, 7.5.4, and 7.5.4.1

The following parts of Section 6: Experimental Procedure of ASTM C1199-09 are amended for this procedure:

7.5.2.1 is replaced with the following:

7.5.2.1(A) Additional temperature measurements shall be made on the surround panel wall. There shall be a minimum of eight temperature sensors, with four at positions bisecting the four lines from the corners of the surround panel aperture to the corresponding corners of the metering area, and four at the positions bisecting the sides of the rectangle having the first four thermocouples at its corners.

7.5.2.2 is replaced with the following:

7.5.2.2(A) When using the CTS Method, the attachment of interior and exterior surface thermocouples to the test specimen shall be voluntary. For the Area-weighted Method it is a requirement to make temperature measurements on the fenestration system frame, glazing (center and near edges) and on any other test specimen surfaces (sills, muntins, etc.), in order to provide a representative area weighted value of the fenestration system surface to surface temperature difference. It must be recognized that there is a wide range of fenestration system designs, therefore it is not possible to specify the locations of the test specimen temperature sensors to provide a correct area weighted determination of the various surface temperatures for all configurations. Area-weighting surface temperature measurements are obtained by placing each predetermined individual temperature sensor in the center of surface area that represents the average temperature of those areas. Consequently, thermocouples may be placed on both horizontal and vertical surfaces depending on the geometry of the test sample. The cross sections in Figure 1 to Figure 7 show typical interior and exterior specimen surface temperature locations. Additional thermocouples may be needed to adequately capture the average temperatures and areas of the test specimen. Each glazing corner edge thermocouple shall be placed at a point 13 mm (1/2 in.) from the adjacent framing. The temperature sensors used shall be at a minimum, special limit (premium) thermocouples 30 gage [0.25476 mm (0.01003 in.)], for surface temperature measurements. Placement shall be as such to minimize the disturbance of the air flows on the surfaces of the test specimen.

7.5.4, 7.5.4.1 are replaced with the following:

7.5.4(A) Wind Speed Measurements -The exterior applied dynamic wind (perpendicular or parallel) shall produce an exterior film coefficient of $30.0 \text{ W}/(\text{m}^2 \cdot ^\circ\text{C})$ ($5.28 \text{ Btu}/\text{h} \cdot \text{ft}^2 \cdot ^\circ\text{F}$) $\pm 10\%$ during calibration testing of a CTS Panel. The weather side wind speed shall be measured in the free stream condition.

- 7.5.4.1(A) The air velocity distribution of the weather side flow field shall be determined in accordance with ASTM C1363, Section 6.8.10.1 with the following provisions for perpendicular flow chambers:
- A. The velocity profile shall be determined at the outlet of the air diffuser system and at least 150 mm (6 in) from any air straighteners.
 - B. For axial flow fans, the measurement locations shall be at the midpoint of the blade at every 30 degrees.
 - C. For centrifugal flow fans or other non-circular fans, the profile shall provide for a minimum of 12 points and not less than 4 per square meter of diffuser outlet.

8. CALCULATION OF THERMAL TRANSMITTANCE

The following parts of Section 8: Calculation of Thermal Transmittance of ASTM C1199-09 are valid for this procedure:

All

9. CALCULATION OF STANDARDIZED THERMAL TRANSMITTANCE

The following parts of Section 9: Calculation of Standardized Thermal Transmittance of ASTM C1199-09 are valid for this procedure:

9.1	Note 13	9.2.1	Note 14
9.2.2	9.2.3	9.2.4	9.2.5
9.2.6	9.2.7	9.2.8	9.2.9

The following parts of Section 9: Calculation of Standardized Thermal Transmittance of ASTM C1199-09 are amended for this procedure:

9.2 is replaced with the following:

9.2(A)The following sections offer two methods of calculating the standardized thermal transmittance. The procedure that utilizes the calculation of the equivalent surface temperatures to compute the test specimen thermal conductance (CTS method) is described in 9.2.1-9.2.3, 9.2.5 and 9.2.7and the method that uses the area-weighted surface temperature measurements to compute the standardized thermal transmittance of the test specimen (area weighting method) is described in 9.2.4, 9.2.6, and 9.2.8. All products shall use the CTS method, except garage (vehicular access) doors and rolling doors. All garage doors and rolling doors shall use the Area Weighting Method specified in ASTM C 1199 to determine the standardized thermal transmittance, U_{ST} . Although the Figures in this section attempt to depict the area weighting and instrumentation scheme for various garage doors, see ASTM E 1423 for additional guidance on

Annex A3. Standard Test Method for Determining the Thermal Transmittance of Tubular Daylighting Devices

A3.1 Scope

- A3.1.1** This appendix covers requirements and guidelines and specifies calibration procedures required for the measurement of the steady-state thermal transmittance of Tubular Daylighting Devices (TDDs). This appendix covers two distinct apparatus setups which are intended to rate the two primary installation methods utilized with these products.
- A3.1.2** The general requirements of testing shall be as defined in NFRC 102, ASTM C1199, and ASTM C1363. This appendix will describe the unique apparatus and testing modifications required to accurately test a TDD. Requirements in this appendix shall supersede the requirements in any other documents.
- A3.1.3** The primary modifications have been made to accommodate the unique product configuration, small product area, and the requirement for three distinct environmental chambers. Unlike other tests using NFRC 102 and ASTM C1199, the hot box apparatus is configured for a test with heat flow in the vertical direction.

A3.2 Apparatus

- A3.2.1** The general concepts and construction specified in ASTM C1363 are applicable to this standard, with some unique modifications. Unlike the standard C1363 apparatus, the TDD hot box apparatus requires three distinct environmental chambers. These chambers are the metering chamber, the attic chamber, and the climatic chamber. The chambers are arranged as shown in Figures A3.1 and A3.2. The same apparatus can be utilized for testing in both configurations and this should be considered during design and construction.

Figure A3.1 -- TDD Hot Box for Testing in the Insulation at Ceiling Configuration

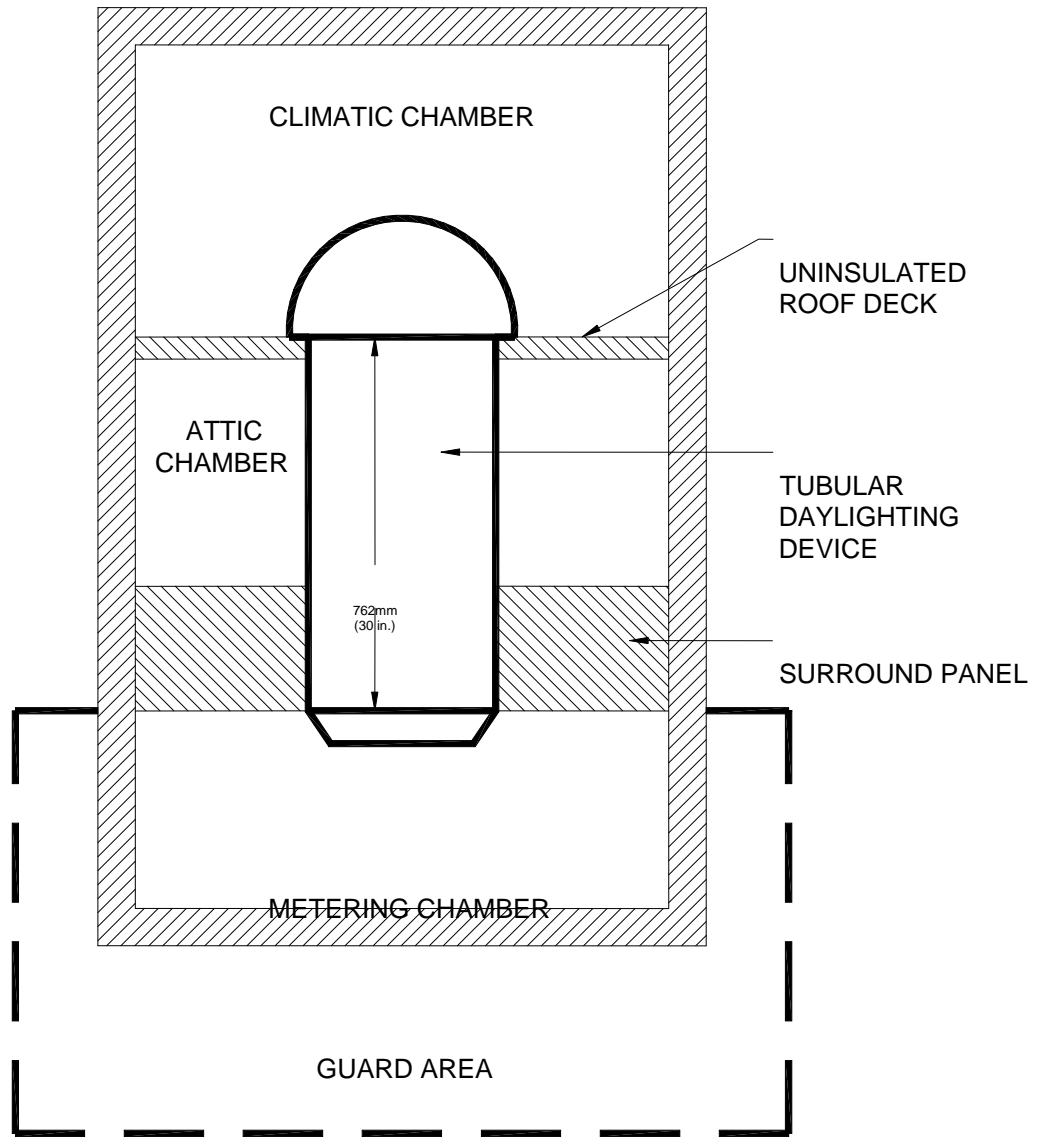
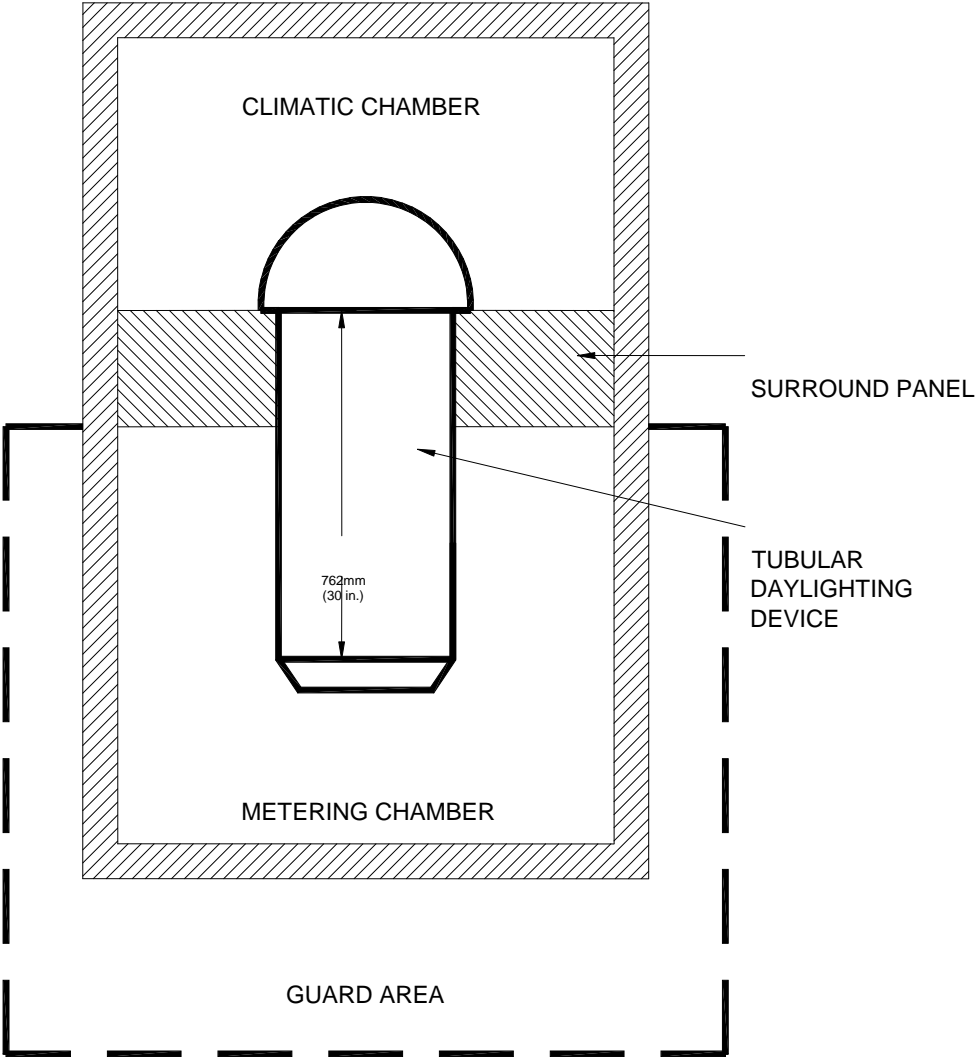

Figure A3.2 -- TDD Hot Box for Testing in the Insulation at Roof Configuration



A3.2.2 The metering chamber shall comply with standard practices for hot box construction as per ASTM C1363, with the following cautions. Due to the very small size and low heat flow of the specimen being tested, the chamber shall be sized to allow for the maximum ratio of heat flow through the specimen to total heat flow. The metering chamber guard area shall be designed and controlled to minimize wall losses. Minimizing the heat flows through the walls and surround panel are critical to achieving acceptable accuracy with this test method.

A3.2.3 The weather side chamber shall comply with standard practices for hot box construction as per ASTM C1363.

A3.2.4 The attic chamber shall comply with all the standard practices for hot box construction as per ASTM C1363 guidelines for the metering chamber.

A3.3 NFRC Test Conditions

A3.3.1 Metering Chamber Conditions

- (1) Interior ambient temperature of $21.0^{\circ}\text{C} \pm 0.3^{\circ}\text{C}$ ($69.8^{\circ}\text{F} \pm 0.5^{\circ}\text{F}$).
- (2) An interior measured film coefficient during CTS panel calibration testing of $7.67 \text{ W/m}^2\cdot^{\circ}\text{C}$ ($1.35 \text{ Btu/hr}\cdot\text{ft}^2\cdot^{\circ}\text{F}$) $\pm 5\%$.

A3.3.2 Climatic Chamber Conditions

- (1) Exterior ambient temperature of $-18.0^{\circ}\text{C} \pm 0.3^{\circ}\text{C}$ ($-0.4^{\circ}\text{F} \pm 0.5^{\circ}\text{F}$).
- (2) An exterior measured film coefficient during CTS panel calibration testing of $30.0 \text{ W/m}^2\cdot^{\circ}\text{C}$ ($5.28 \text{ Btu/hr}\cdot\text{ft}^2\cdot^{\circ}\text{F}$) $\pm 10\%$.

A3.3.3 Attic Chamber Conditions

- (1) Attic ambient temperature of $-18.0^{\circ}\text{C} \pm 0.1^{\circ}\text{C}$ ($-0.4^{\circ}\text{F} \pm 0.2^{\circ}\text{F}$).
- (2) An attic measured film coefficient during CTS panel calibration testing of $12.5 \text{ W/m}^2\cdot^{\circ}\text{C}$ ($2.20 \text{ Btu/hr}\cdot\text{ft}^2\cdot^{\circ}\text{F}$) $\pm 5\%$.

A3.4 Calibration

A3.4.1 Calibration Transfer Standards – The unique geometry of TDDs requires the use of a very unique CTS panel. The CTS is constructed of three sections as detailed below and in Figures A3.3, A3.4, and A3.5. All panels shall be constructed using a 12.7 mm (0.5 in) thick core material and 3 mm (0.125 in) facing material. All thermocouples shall be mounted on the exterior of the facing materials. The thermal conductance of the CTS core, C_{ts} , and the CTS assembly, $C_{ts[assembly]}$, shall be measured as specified in Annex A.1 of ASTM C 1199.

A3.4.1.1 Metering Chamber CTS – This panel is shown in Figure A3.3 and is the most standard of the three required CTS constructions, representing the interior diffuser of the TDD. The panel shall be 343 mm x 343 mm (13.5 in x 13.5 in), and shall be instrumented with nine thermocouples. It shall be mounted inset in the surround panel so that the face of the

CTS in the metering room is flush with the face of the surround panel.

Figure A3.3 Metering Chamber Calibration Transfer Standard



METERING CHAMBER
SIDE VIEW OF CTS PANEL INSTALLED IN SURROUND PANEL

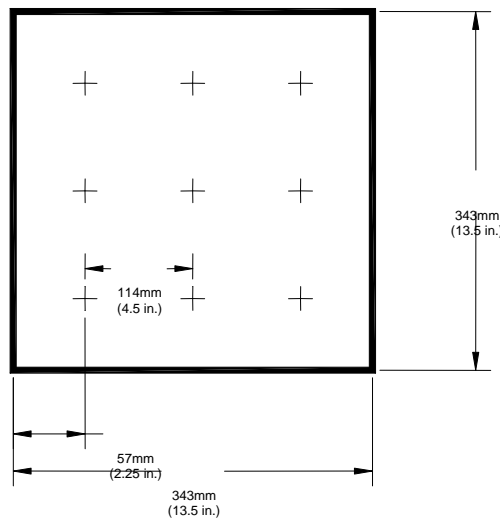

TOP VIEW

A3.4.1.2 Climatic Chamber CTS – This panel is shown in Figure A3.4 and is the most unique of the three required CTS constructions, representing the exterior dome of the TDD. This panel is pyramidal in shape, with four equal triangular sides. It shall be 203 mm (8 in) in height, when assembled,

with a 457 mm x 457 mm (18 in x 18 in) base and shall be instrumented with twelve thermocouples, three on each face.

Figure A3.4 -- Climatic Chamber Calibration Transfer Standard

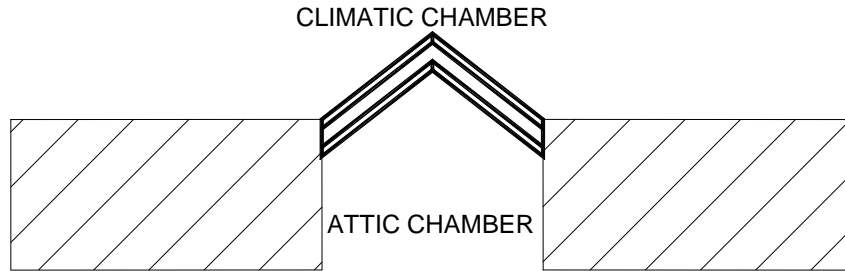

SIDE VIEW OF CTS PANEL INSTALLED IN SURROUND PANEL

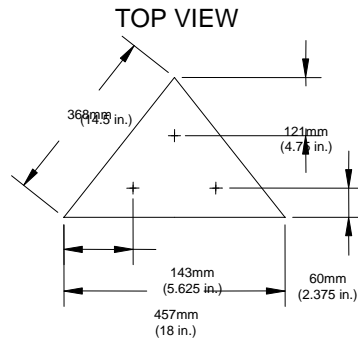
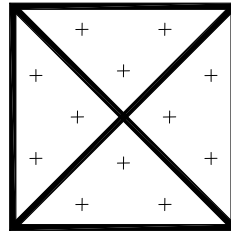

PANEL LAYOUT

A3.4.1.3 Attic Chamber CTS – This panel is shown in Figure A3.5 and is like four standard CTS joined into a tube, representing the tube of the TDD. The panel shall be 38.1 mm x 38.1 mm (15 in x 15 in) and shall be instrumented with twelve thermocouples.

Figure A3.5 -- Attic Chamber Calibration Transfer Standard

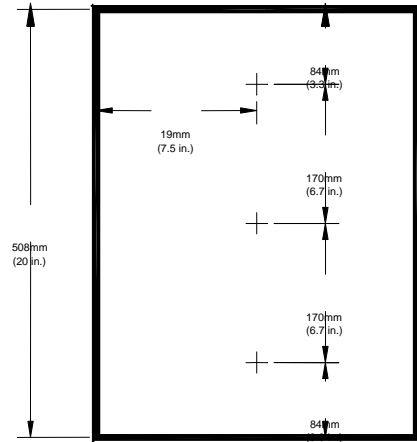

SIDE VIEW

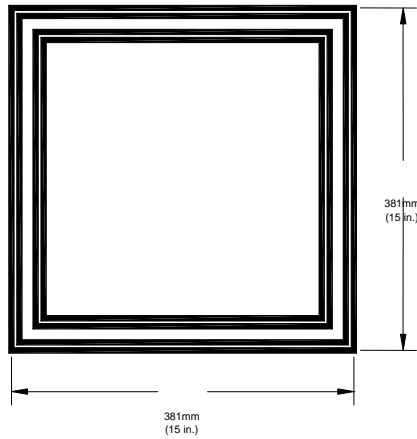

TOP VIEW

A3.4.2 Calibration Tests – There are two distinct testing configurations required for TDDs. The metering box wall characterization shall be performed as specified in ASTM C1363 for both testing configurations. Three distinct surface heat transfer coefficients representing the climate, attic and metering chambers shall also be determined for each testing configuration.

Full characterization will require the following tests:

- (1) Metering Box Wall and Flanking Loss Calibration as specified in ASTM C1363, three tests covering a full range of expected EMF, in the Insulation at Ceiling Configuration
- (2) Metering Box Wall and Flanking Loss Calibration as specified in ASTM C1363, three tests covering a full range of expected EMF, in the Insulation at Roof Configuration
- (3) Climatic Chamber CTS Surface Heat Transfer Verification at the conditions specified in section A3.3
- (4) Attic Chamber CTS Surface Heat Transfer Verification at the conditions specified in section A3.3.
- (5) Metering Chamber CTS Surface Heat Transfer Verification at the conditions specified in section A3.3.

The CTS calibration setups are shown in Figures A3.6, A3.7, and A3.8. Metering Box Wall and Flanking Loss shall be calculated as described in ASTM C1363. The surface heat transfer coefficients shall be calculated as described in the following sections. The CTS calibration is an iterative process, which may require adjustment of each individual chamber. The final surface heat transfer coefficients shall be determined and reported for all three panels, after all adjustments have been made.

A3.4.2.1 *Room side surface heat transfer coefficient, h_h* is calculated as follows:

$$h_h = Q_{sm} / (A_{sm} \cdot (t_h - t_{1m})) \quad \text{(A3.1)}$$

Where:

Q_{sm} = Metering Chamber CTS heat flow, calculated from:

$$Q_{sm} = C_{ts[assembly]} \cdot A_{sm} \cdot (t_{1m} - t_{2m}) \quad \text{(A3.2)}$$

A_{sm} = Area of the exposed cold side of the Metering Chamber CTS

t_{1m} = Area weighted average temperature of the warm side of the Metering Chamber CTS

t_{2m} = Area weighted average temperature of the cold side of the Metering Chamber CTS

A3.4.2.2 *Weather side surface heat transfer coefficient, h_c* is calculated as follows:

$$h_c = Q_{sc} / (A_{sc} \cdot (t_{2c} - t_c)) \quad \text{(A3.3)}$$

Where:

Q_{sc} = Climatic Chamber CTS heat flow, calculated from:

$$Q_{sc} = C_{ts[assembly]} \cdot A_{sc} \cdot (t_{1c} - t_{2c}) \quad \text{(A3.4)}$$

A_{sc} = Area of the warm side of the Climatic Chamber CTS panel

t_{1c} = Area weighted average temperature of the warm side of the Climatic Chamber CTS

t_{2c} = Area weighted average temperature of the cold side of the Climatic Chamber CTS

A3.4.2.3 *Attic side surface heat transfer coefficient, h_a* is calculated as follows:

$$h_a = Q_{sa} / (A_{sa} \cdot (t_{2a} - t_a)) \quad \text{(A3.5)}$$

Where:

Q_{sa} = Attic Chamber CTS heat flow, calculated

$$Q_{sa} = C_{ts[\text{assembly}]} \cdot A_{sa} \cdot (t_{1a} - t_{2a}) \quad \text{(A3.6)}$$

A_{sa} = Area of the warm side of the Attic Chamber CTS panel

t_{1a} = Equal area weighted average temperature of the warm side of the Attic Chamber CTS

t_{2a} = Equal area weighted average temperature of the cold side of the Attic Chamber CTS

Figure A3.6 -- Climatic Chamber CTS Installation

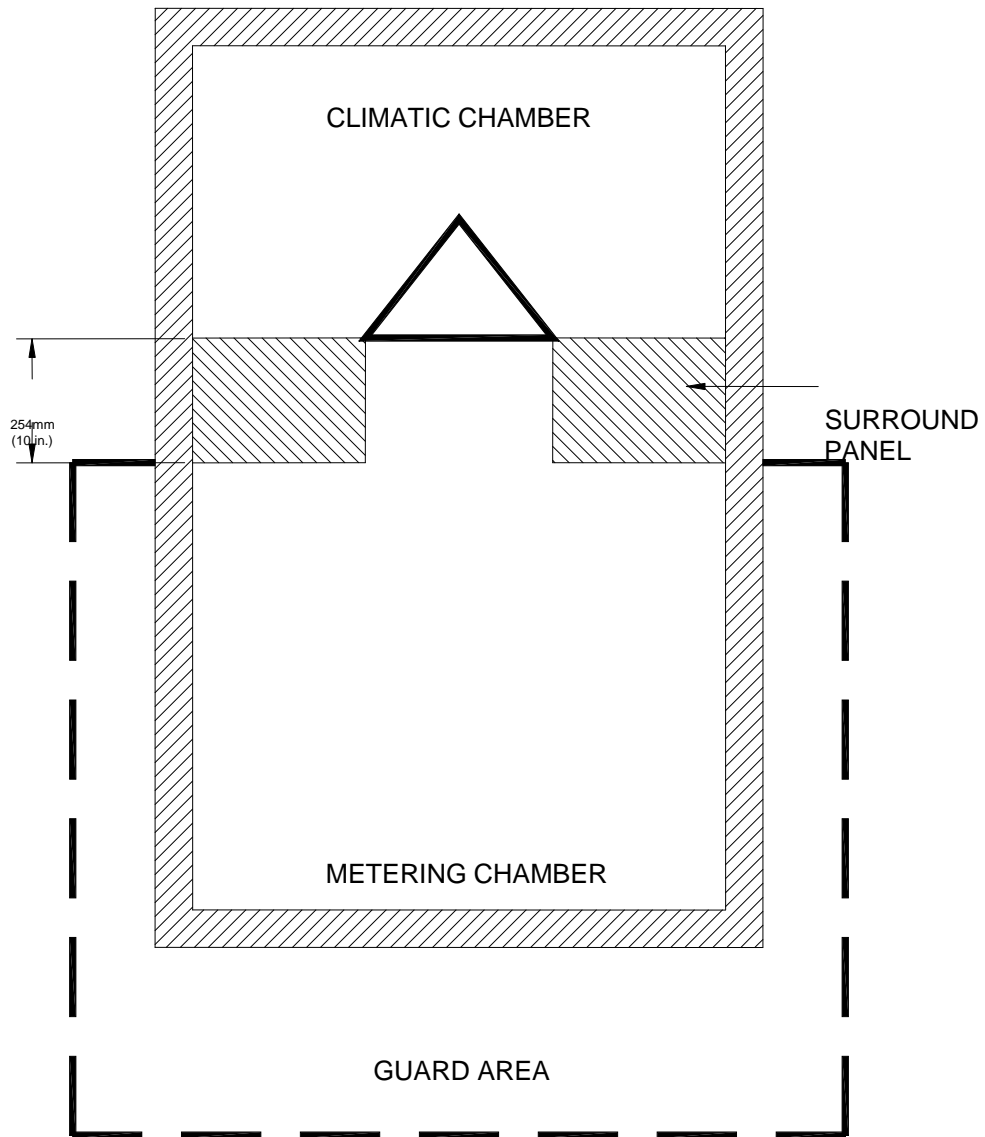

Figure A3.7 -- Attic Chamber CTS Installation

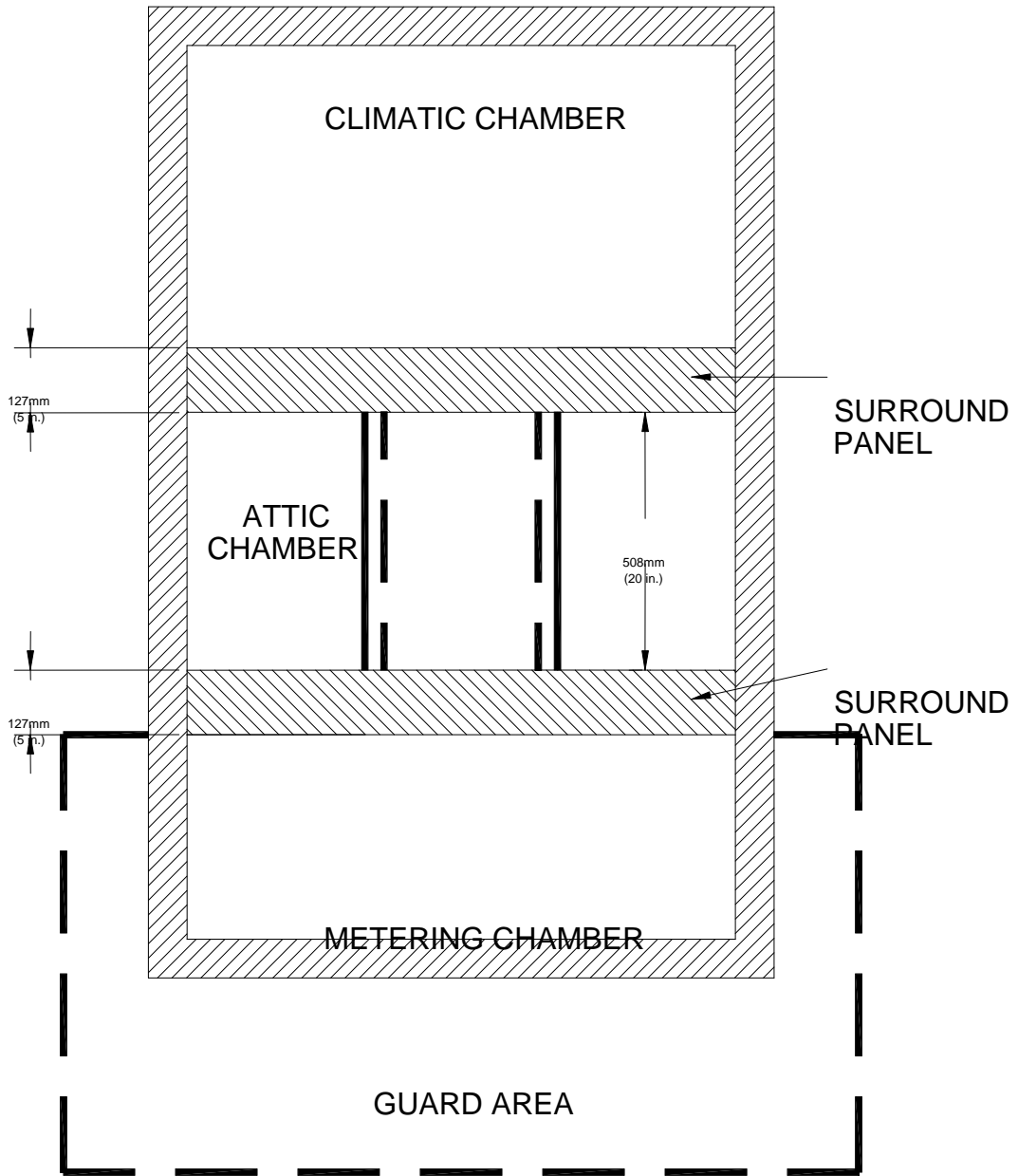
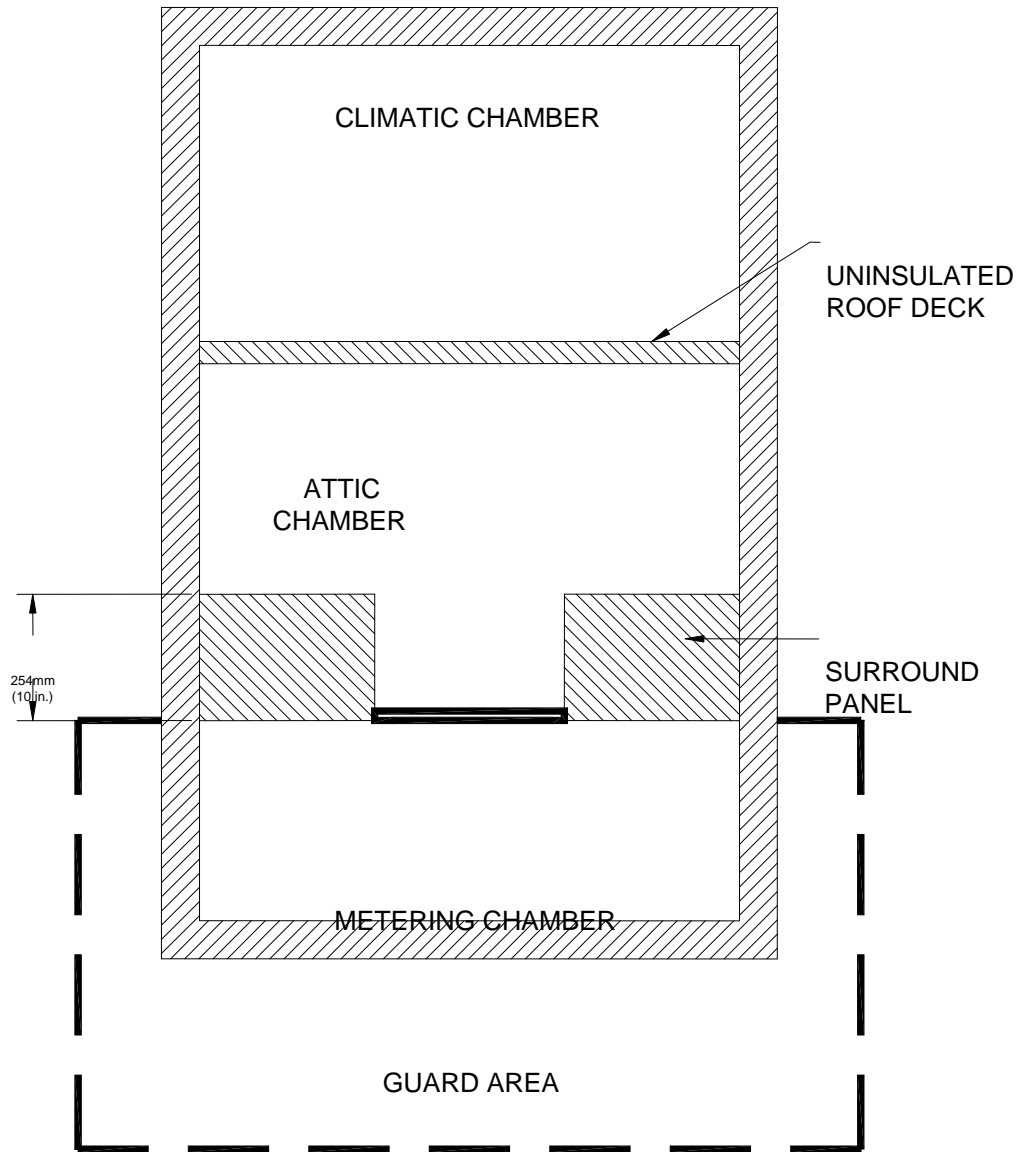

Figure A3.8 -- Metering Chamber CTS Installation



A3.5 Calculation of Thermal Transmittance

A3.5.1 *Test Specimen Thermal Transmittance, U_s* , is calculated as follows:

$$U_s = Q_s / (A_t \cdot (t_h - t_c)) \quad \text{(A3.7)}$$

Where:

A_t = Projected TDD Tube Area, based on outside tube diameter

A3.5.2 A Test Specimen Standardized Thermal Transmittance, U_{st} , cannot be calculated for this product.

Annex A4. Garage Panel and Rolling Door Installation

The door will be secured to a nominal 2 x 4 side and top wood framing, and supported on the bottom by a nominal 2 x 6 wood sill. These wood framing components are installed within the aperture of the surround panel in an ASTM C 1363 and ASTM C 1199 thermal chamber. The warm side surface of the top and side wood framing is placed so that it is flush with the warm side surface of the surround panel.

NOTE: Not only are these wood framing components intended to increase the structural rigidity of the 100 mm (4 in.) thick surround panel, but they also provide a means to secure the top and the sides of the test specimen. The garage door can be attached to the top and side wood framing using fasteners placed at regular intervals that pass through the edge of the garage door test specimen into the wood framing. Ensure that the door is placed so that the bottom weather-stripping of the door creates a seal on the nominal 2 x 6 wood sill. Additional sealing can be performed by taping or caulking the edges and gaps on the warm side.

Annex A5. Tables and Figures

Figure A5-1 -- Thermocouple Location Two-Lite Curtain Wall, Patio Door

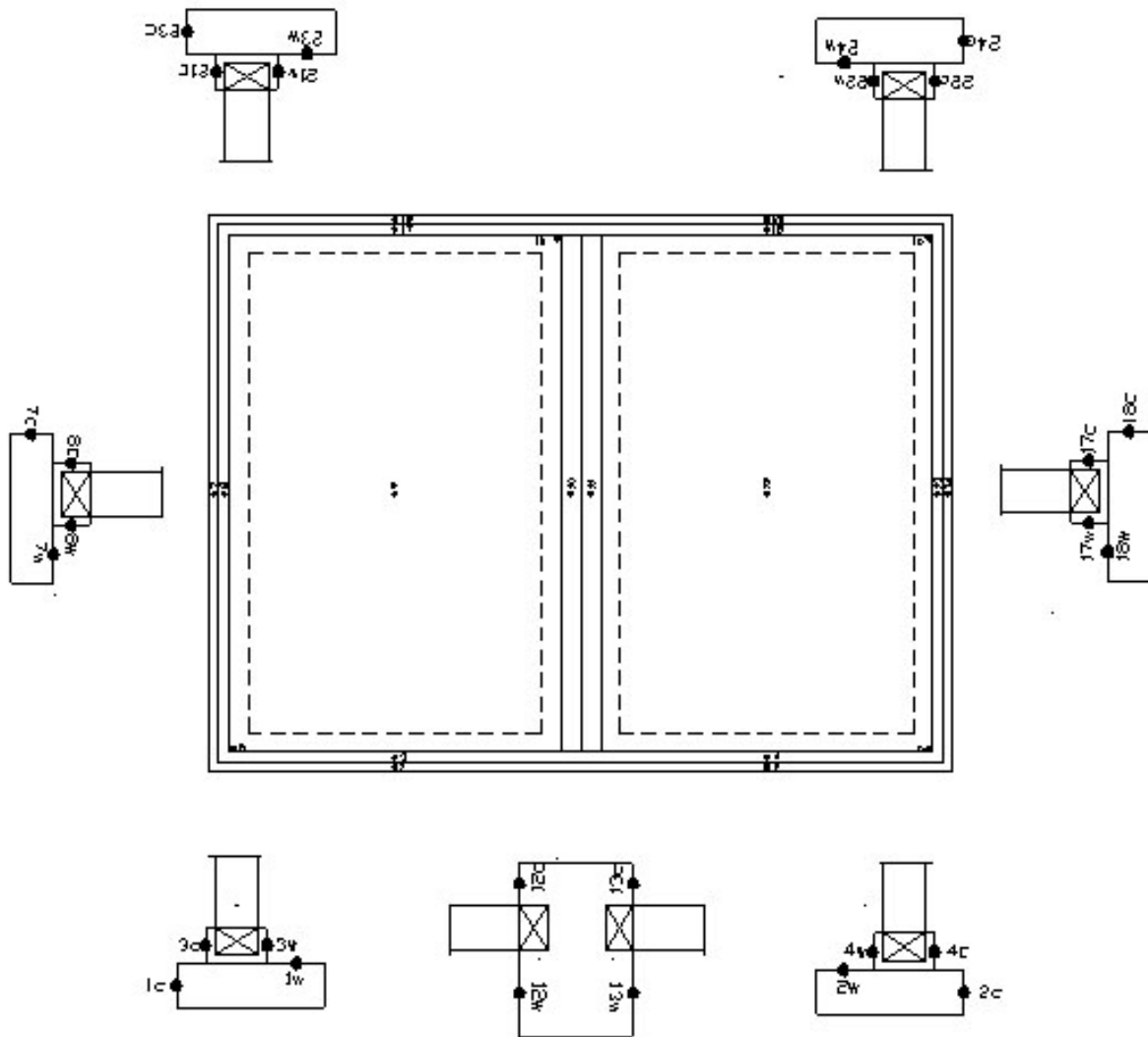

Figure A5-2 -- Thermocouple Location Casement, Projected (Awning)

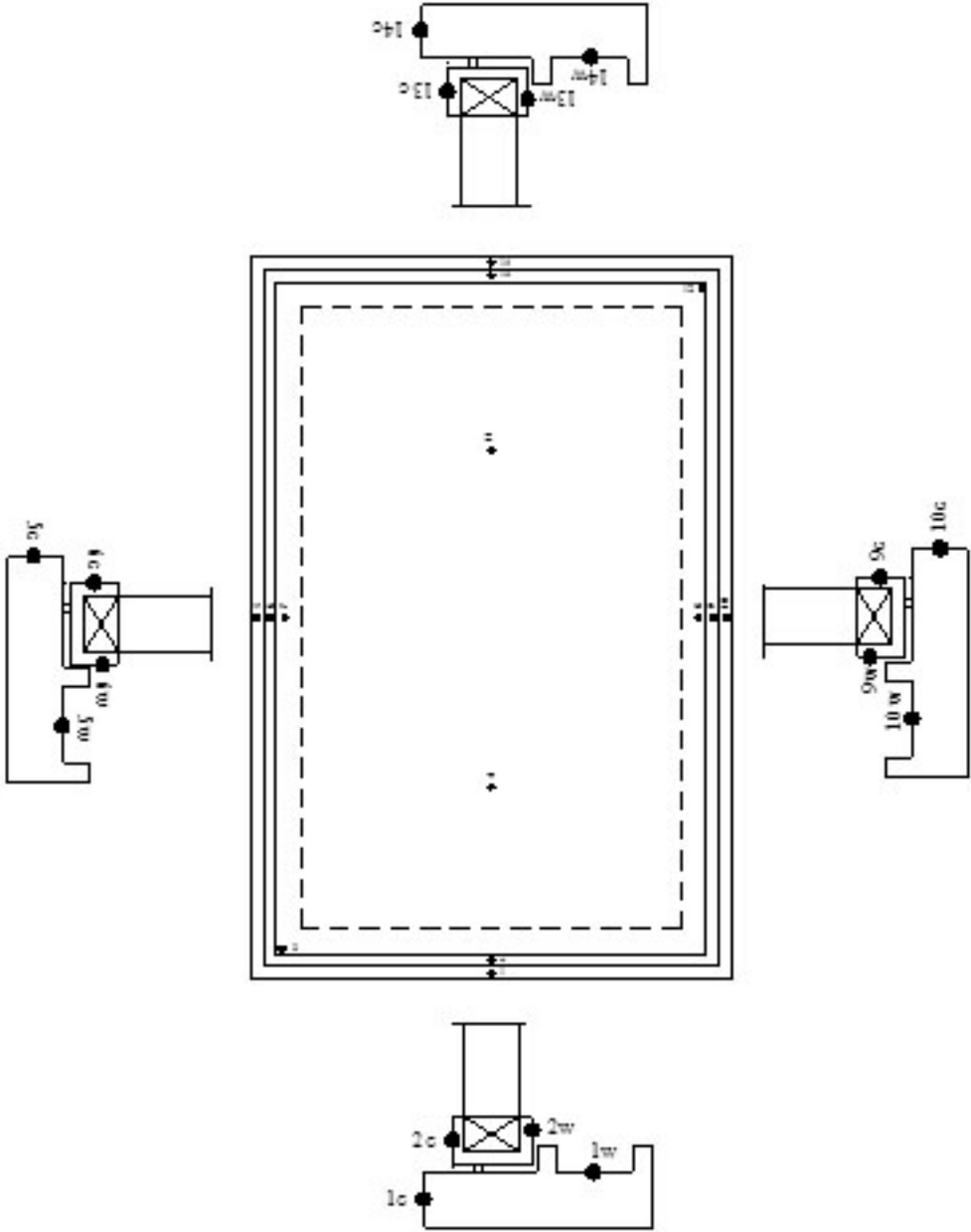

Figure A5-3 -- Thermocouple Location Fixed

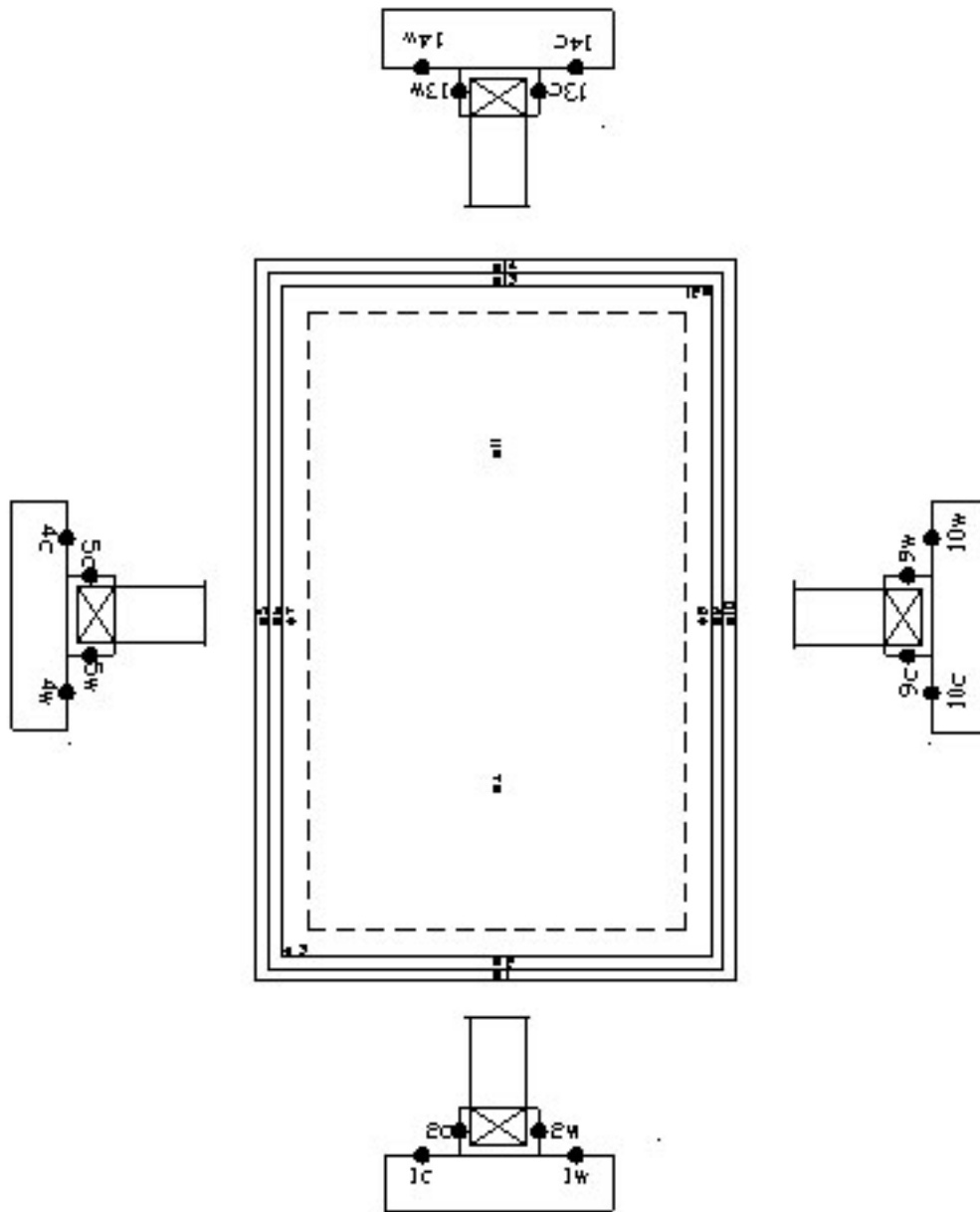

Figure A5-4 -- Thermocouple Location Horizontal Slider

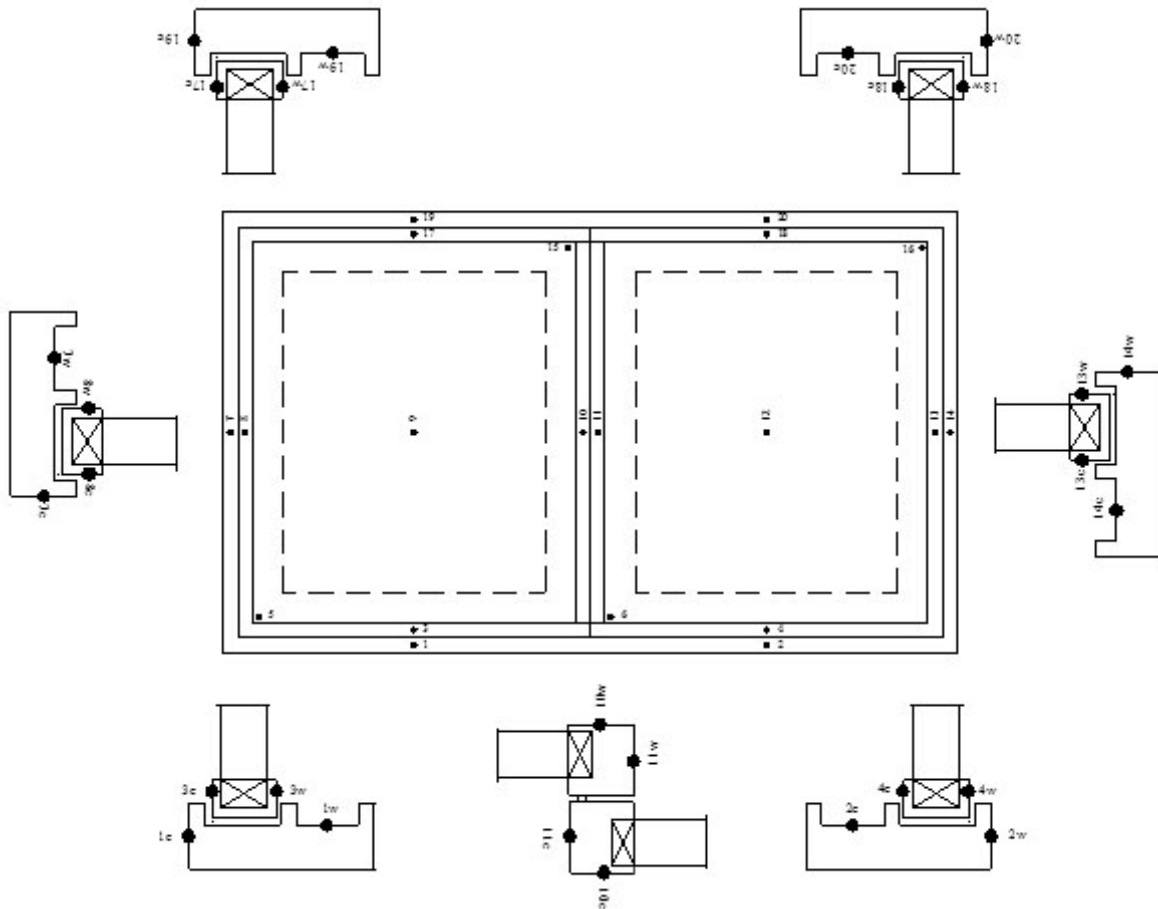

Figure A5-5 -- Thermocouple Location Vertical Slider

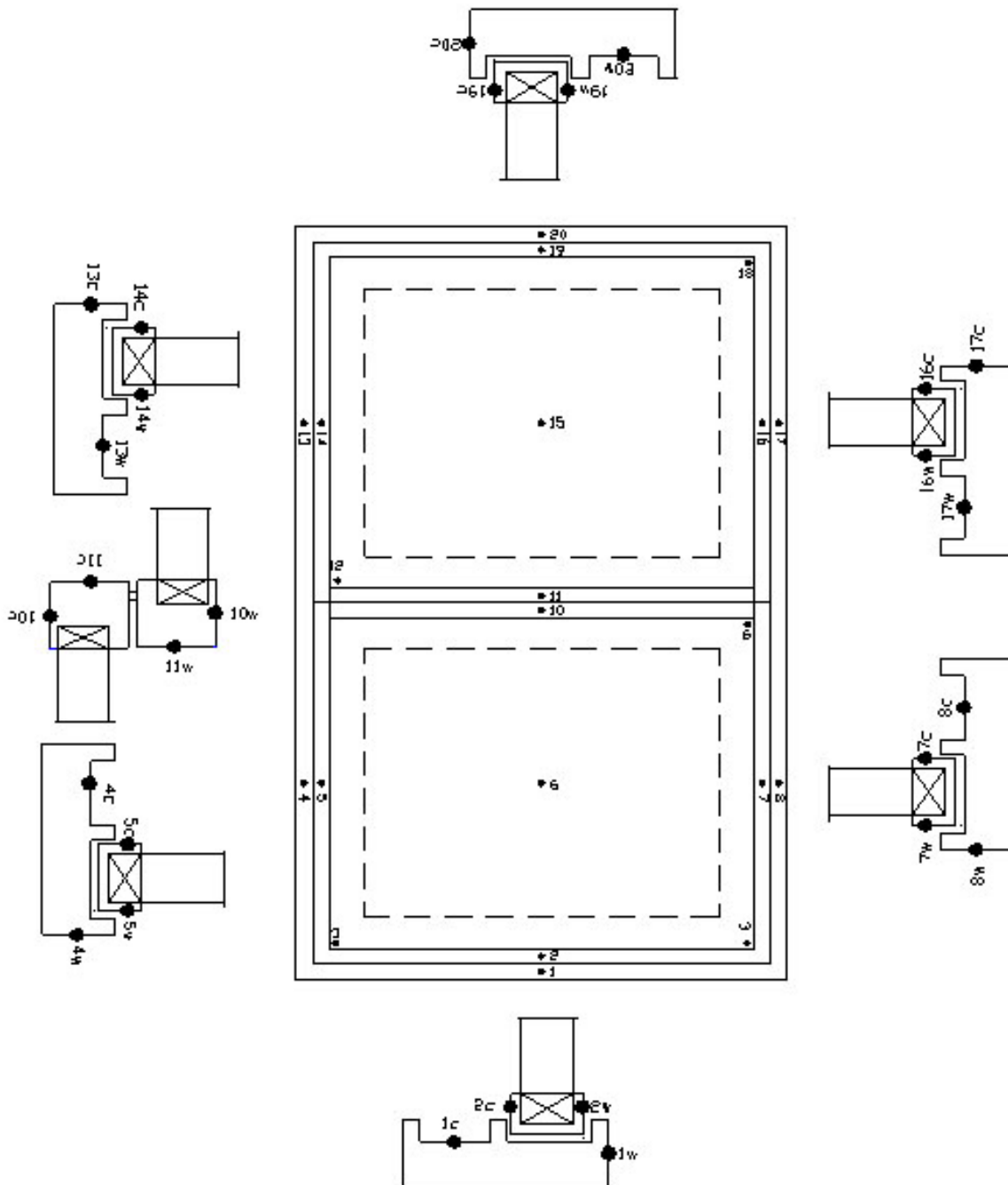

Figure A5-6 -- Thermocouple Location Entrance Door

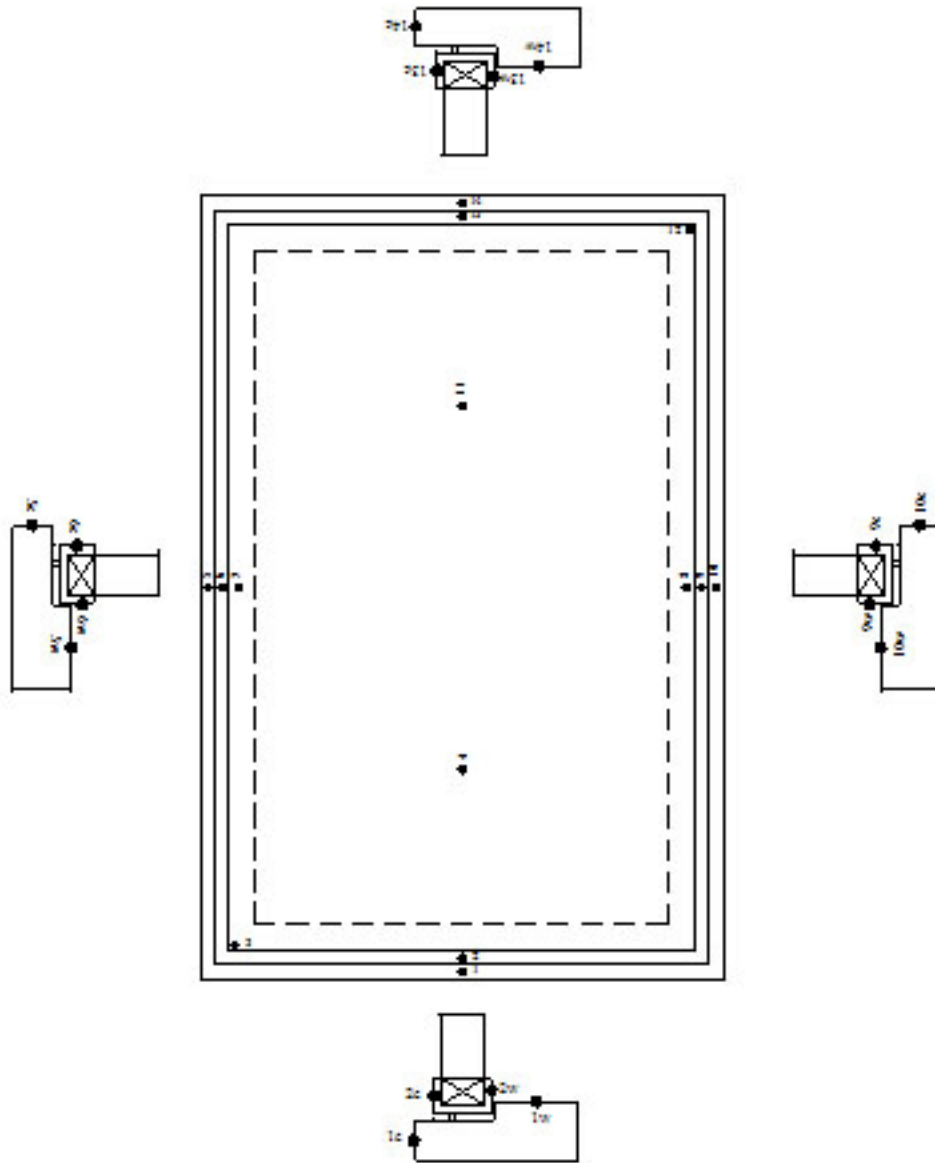

Figure A5-7: Thermocouple Location Divider

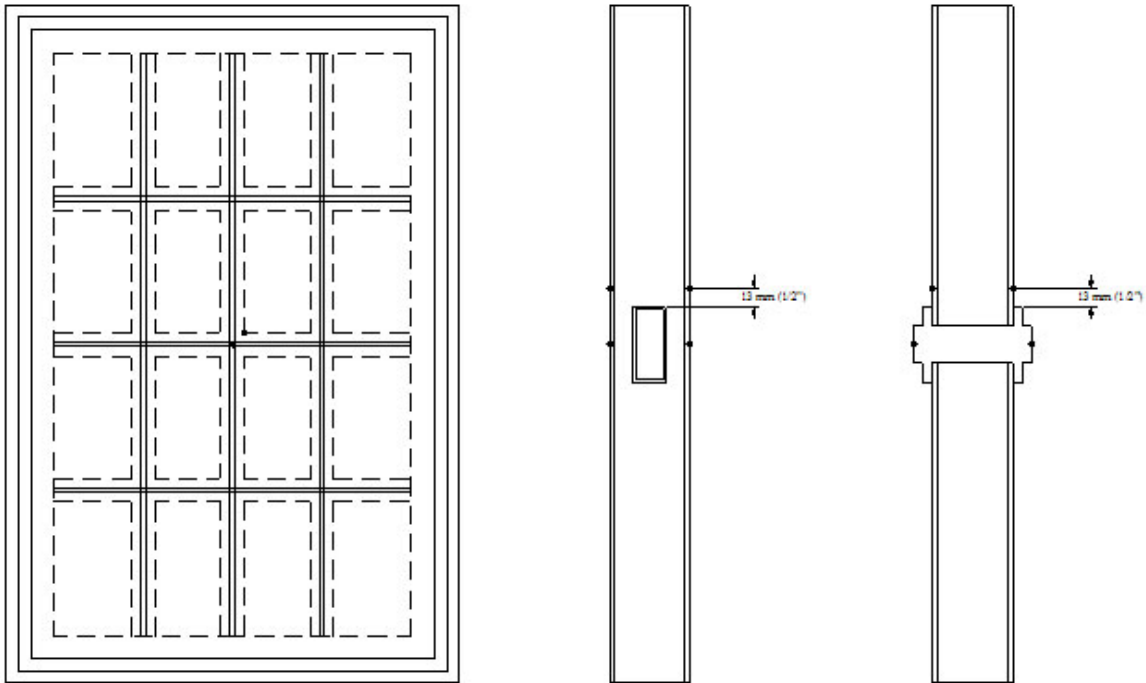
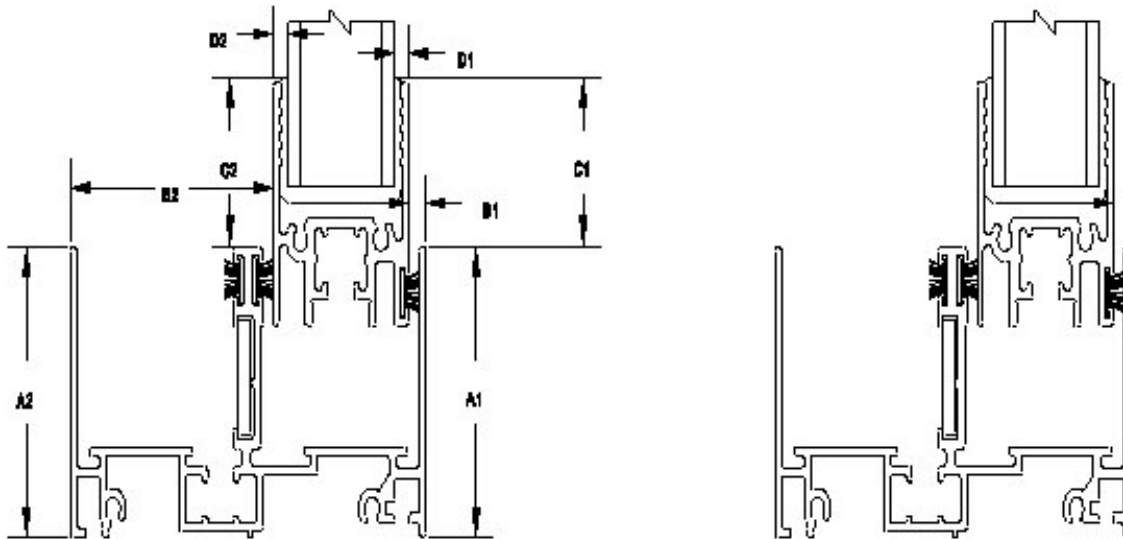

Figure A5-8 -- Example of Method to Determine Interior and Exterior Wetted 2-D Surface Areas



Area for the frame shall be calculated as
[projected height (A*) + projected depth (B*)] × assigned length of the section

Area for the sash shall be calculated as
[projected height (C*) + projected depth (D*)] × assigned length of the section

A1" designates as interior projected profile

A2" designates as exterior projected profile

Figure A5-9 -- Garage Door Installation

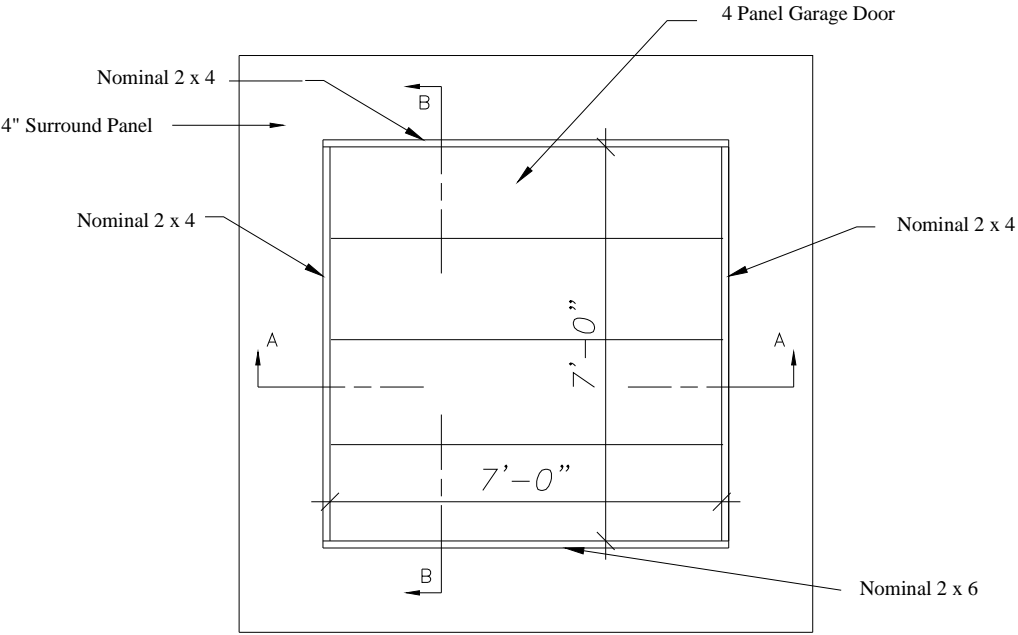

EXTERIOR ELEVATION

N.T.S.

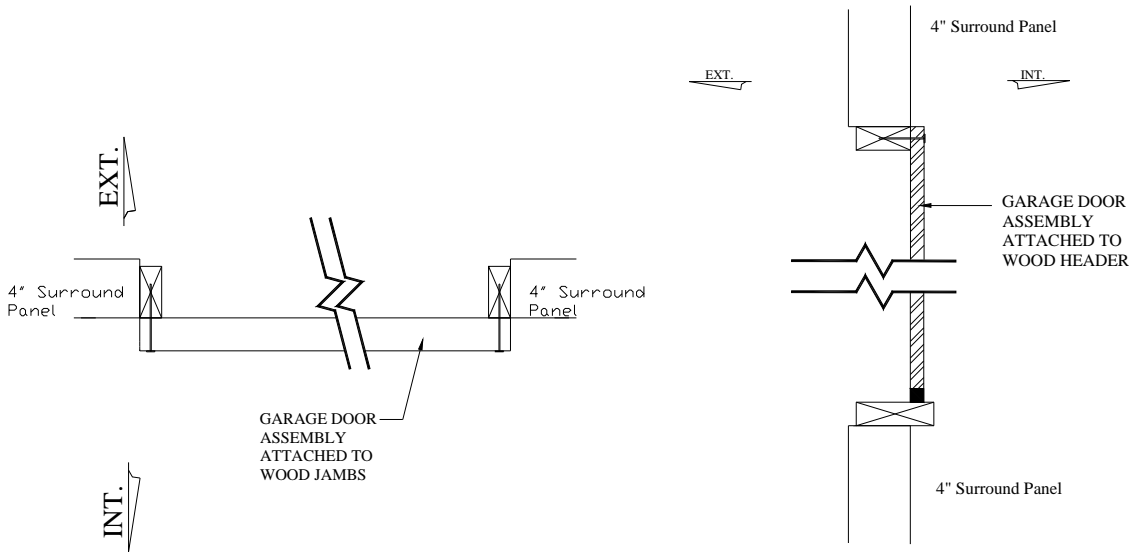

SECTION A-A

N.T.S.

SECTION B-B

N.T.S.

Figure A5-10 -- Thermocouple Location Four Panel Garage Door

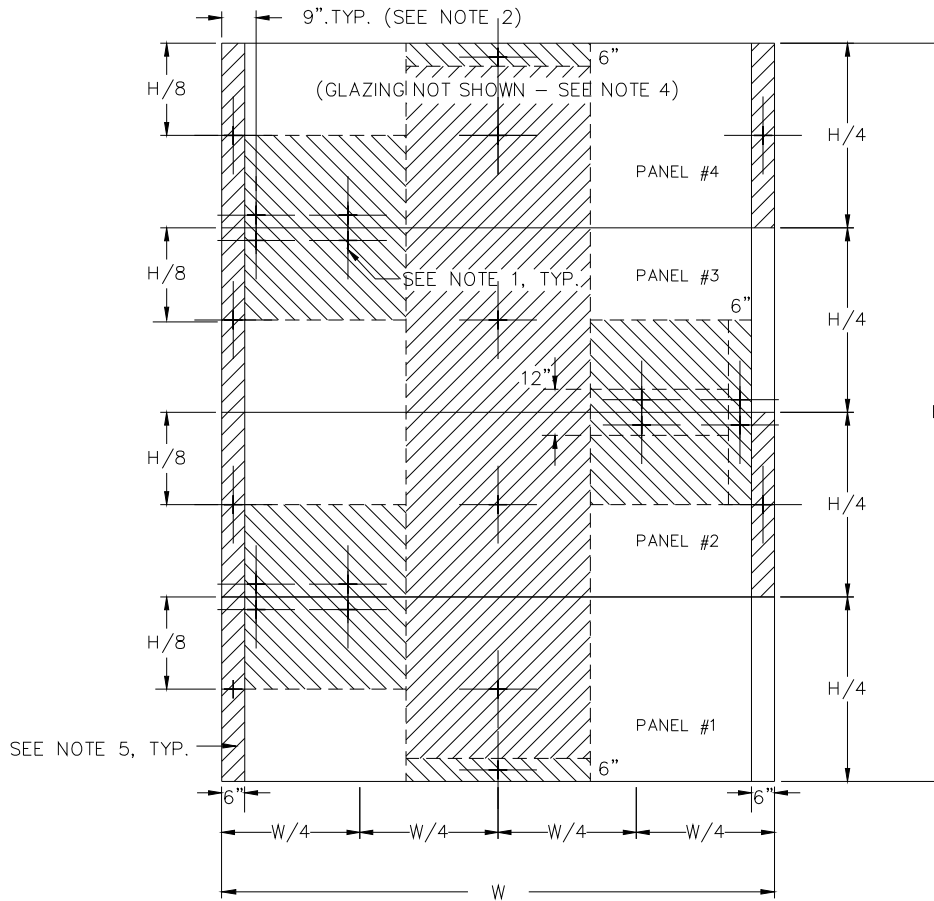

- NOTE:
1. PANEL PERIMETER THERMOCOUPLES SHALL BE LOCATED 3" FROM PANEL EDGES UNLESS OTHERWISE NOTED.
 2. THERMOCOUPLES NEAR JAMB LOCATIONS SHALL BE PLACED ON PANEL SKIN MATERIAL AT THE THINNEST DOOR SECTION.
 3. NUMBER AND LOCATION OF THERMOCOUPLES MAY VARY, DEPENDENT UPON THE DESIGN OF THE GARAGE DOOR.
 4. WHEN GLAZING IS USED, THERMOCOUPLES FOR EACH LIGHT SHALL INCLUDE ONE IN THE CENTER AND TWO AT THE EDGES. ONE OF THE TWO AT THE EDGE SHALL BE LOCATED AT $\frac{1}{2}$ " FROM A LOWER CORNER AND THE SECOND SHALL BE LOCATED $\frac{1}{2}$ " FROM THE OPPOSITE UPPER CORNER.
 5. TRIBUTARY AREAS INDICATE REPRESENTATIVE AREAS ASSOCIATED WITH THERMOCOUPLES IN SUCH AREAS, USED IN AREA-WEIGHTING CALCULATIONS.

INTERIOR ELEVATION VIEW

Perimeter edge TC locations are 32 mm (1.25 in)

Not all thermocouple locations may be necessary dependent upon the design of the garage door. Glazing TCs shall have 2 edge and 1 center.

Figure A5-11 -- Rolling Door Installation

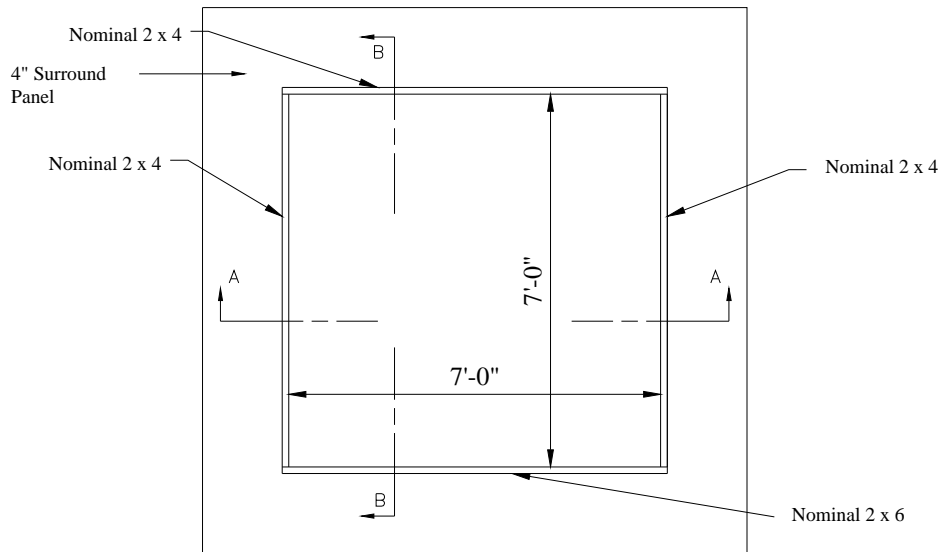

EXTERIOR ELEVATION

Door not shown N.T.S.

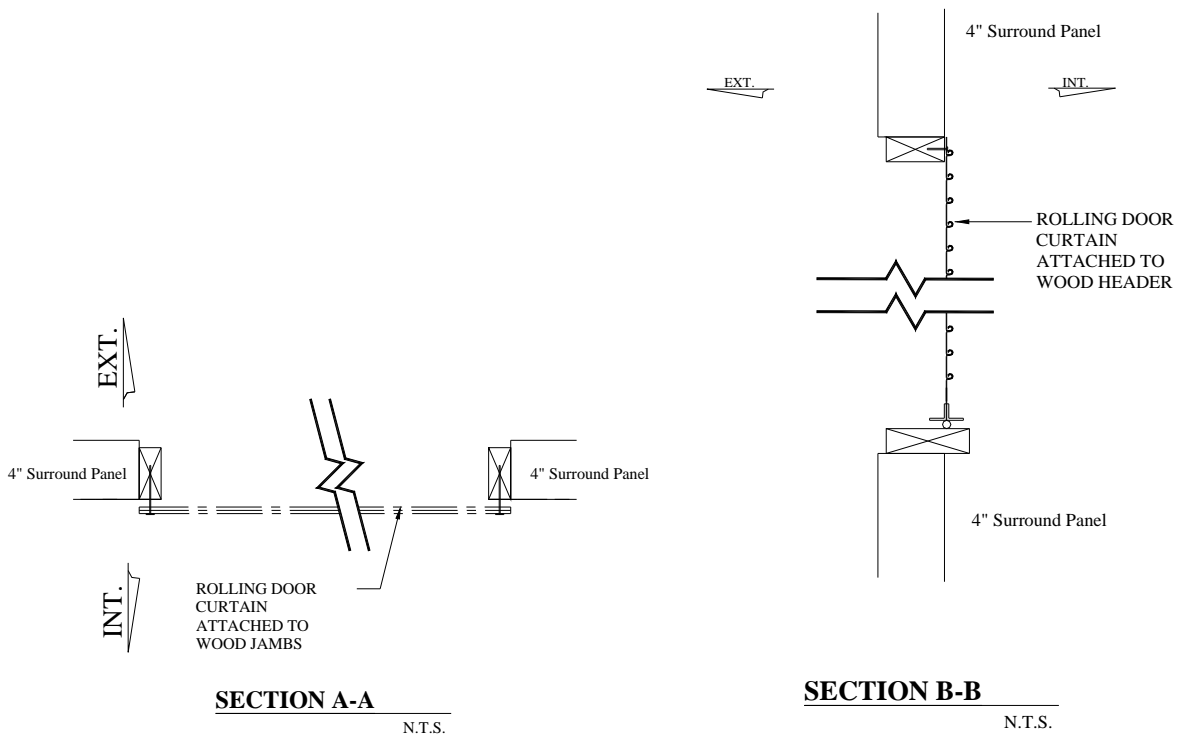
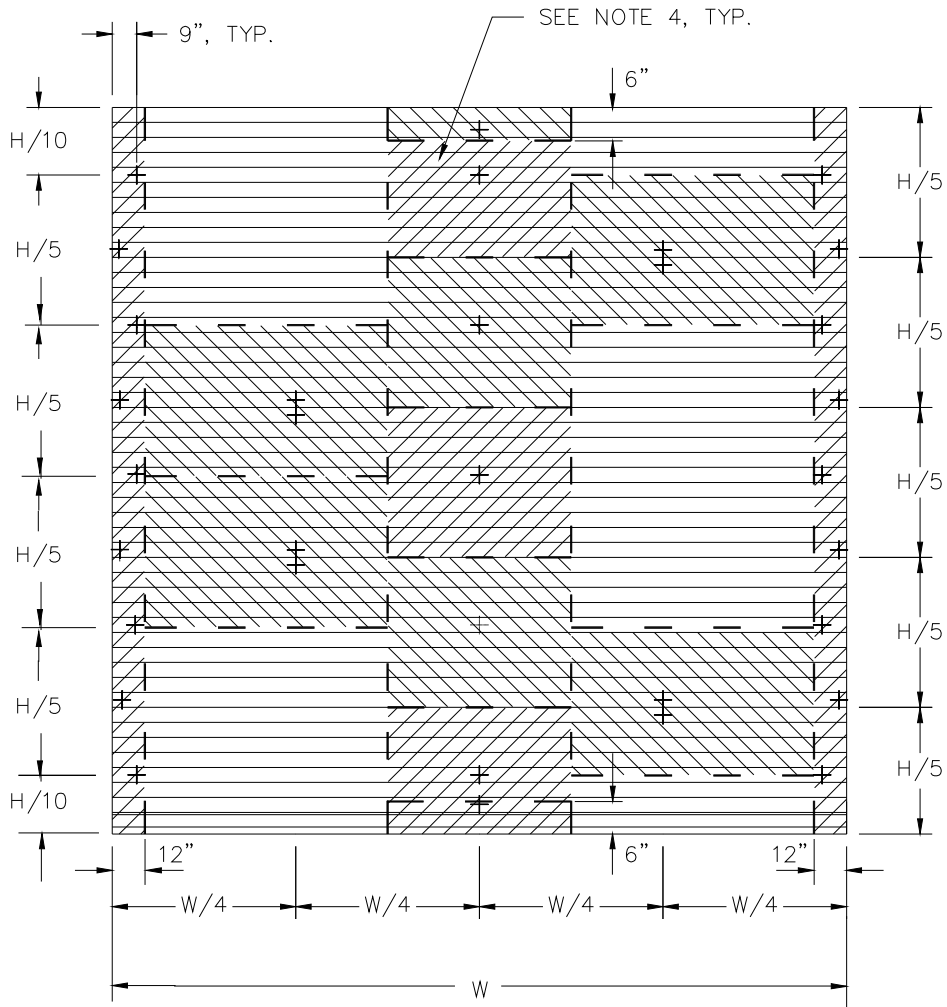

Figure A5-12 -- Thermocouple Locations for Garage Doors



NOTE:

1. DOOR PERIMETER THERMOCOUPLES SHALL BE LOCATED 3" FROM EDGES OF CLEAR OPENING UNLESS OTHERWISE NOTED.
2. DOOR THERMOCOUPLES SHALL BE CENTERED VERTICALLY ON EACH DOOR SLAT.
3. NUMBER AND LOCATION OF THERMOCOUPLE LOCATIONS MAY VARY, DEPENDENT UPON THE DESIGN OF THE ROLLING DOOR.
4. TRIBUTARY AREAS INDICATE REPRESENTATIVE AREAS ASSOCIATED WITH THERMOCOUPLES IN SUCH AREAS, USED IN AREA-WEIGHTING CALCULATIONS.

INTERIOR ELEVATION VIEW

BIBLIOGRAPHY

All Bibliography references of ASTM C1199-09 are valid for this procedure. The following references are in addition to those listed in ASTM C1199-09.

INDEX

Air leakage	8	NFRC 101	12
Air temperatures.....	8	Projecting Products.....	5
area-weighting.....	4	skylight size	10
ASTM C1363.....	ii, 4, 9	skylights	5, 10
AW	4	Skylights	10
Calibration Transfer Standard	4, 8	surround panel.....	5, 7, 8, 9, 10, 11, 12
Calibration Transfer Standard (CTS)	4	test specimen..	4, 5, 6, 7, 8, 11, 12, 13, 14, 15
Curb Mounted	10	Test specimen	4
enclosed air space	12, 13	U-factor	10
glazing unit.....	12, 13	View Factor.....	5
homogeneous insulation	7	Weep holes/slots	8
NFRC 100	6, 8, 10, 15		